

The Digital Transformation Series

Enterprise Architecture

- ✧ Why do we need Enterprise Architecture (EA)?
- ✧ What is an Enterprise Architecture and Key Benefits?
- ✧ Enterprise Reference Model (ERM)
- ✧ Building Your Enterprise Architecture
- ✧ Enterprise Architecture and The Enterprise Master Plan

อ.दनัยรัฐ ฌนบด็ชรรมจาร์

+668-1559-1446 Line ID: danairat

FB: www.facebook.com/tdanairat

Enterprise Architecture

What is an Enterprise Architecture?

A structure design to ensure alignment between the business and IT strategies



สถาปัตยกรรมด้าน IT/Digital ให้กับองค์กร เพื่อเป็นโครงสร้างในการต่อยอดธุรกิจได้อย่าง
ยั่งยืน

Enterprise Architecture

Enterprise Architecture is a structure design to ensure **alignment between the business and IT strategies** plus operating model, guiding principles.

Enterprise Architect

Responsibilities

- Understanding of business needs and technology limitations
- Facilitating experts to work for enterprise goals
- Promoting of shared infrastructures and applications
- Managing of the risks associated with information and IT
- Building staff knowledges and skills in specific areas.
- Involving in the standards and policy guidelines.

without EA vs. with EA

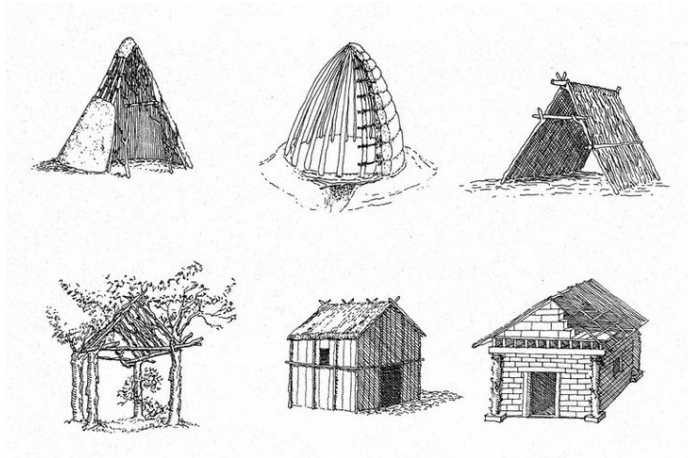

Quick build and difficult to scale

VS.

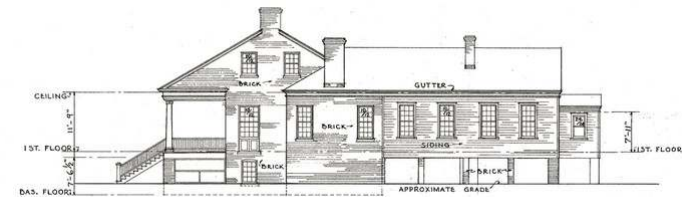

RIGHT SIDE ELEVATION
SCALE 1/8" = 1'-0"

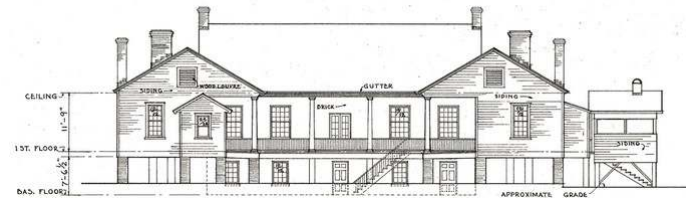

Design for scale and maintain

without EA vs. with EA



VS.



Quick build and difficult to scale
Difficult to apply security

Design for scale and maintain
Secure architecture for growth

without EA vs. with EA

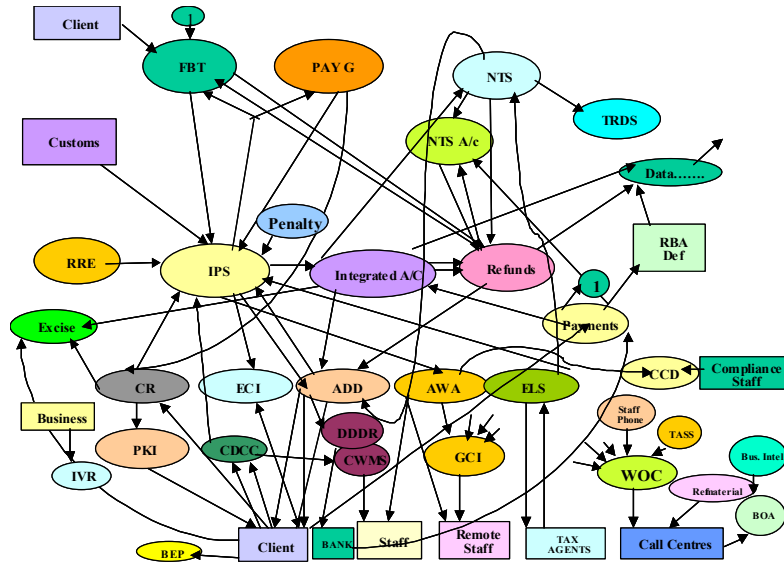

VS.

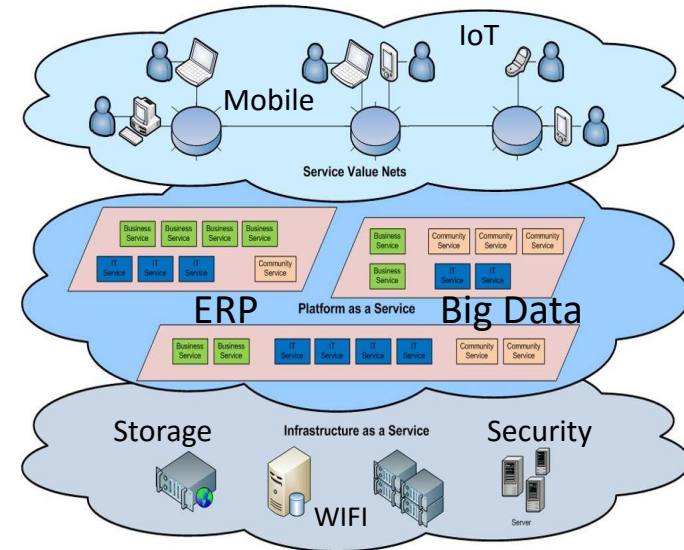

Without Enterprise Architecture

Inefficient IT

Complex and Delay Response

With Enterprise Architecture

Productive IT

Cloud, Big Data, Social, Mobile

พัฒนาการของการใช้ไอทีในองค์กร

Silo

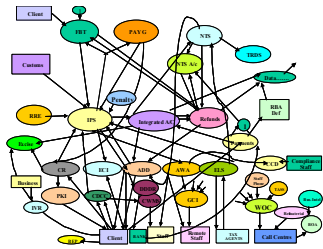

- ต่างคนต่างทำ แล้ว
มาเชื่อมกันทีหลัง
- ระบบงานกระจัด
กระจาย เชื่อมต่อกัน
ขาดมาตรฐาน
- เปลี่ยนแปลงยาก
- ขยายระบบยาก
- ใช้เวลามากในการ
จัดการ และ
แก้ปัญหา
- มีความเสี่ยงสูง

พัฒนาการของการใช้ไอทีในองค์กร

Silo

Standardization

Optimization

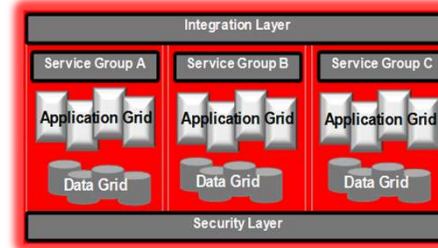
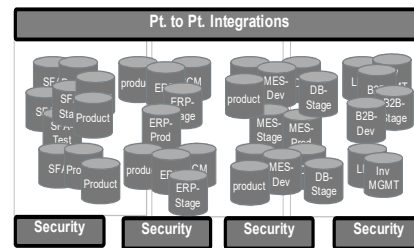
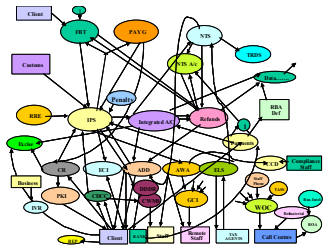

- ต่างคนต่างทำ แล้วมาเชื่อมกันทีหลัง
- ระบบงานกระจาย กระจาย เชื่อมต่อกันขาดมาตรฐาน
- เปลี่ยนแปลงยาก
- ขยายระบบยาก
- ใช้เวลามากในการจัดการ และแก้ปัญหา
- มีความเสี่ยงสูง

- จัดกลุ่มกระบวนการทำงาน และทรัพยากรไอที
- มีมาตรฐานในการรับส่งข้อมูล
- ประหยัดค่าใช้จ่ายด้าน SW License และ support
- ลดต้นทุนด้าน IT project time/costs/risks

- ตัดกระบวนการทำงานที่ซ้ำซ้อน
- ลดทรัพยากรทางไอทีที่ไม่จำเป็น
- ผลิตบริการด้านไอทีได้เร็วขึ้น
- เพิ่มความปลอดภัยด้านไอที

พัฒนาการของการใช้ไอทีในองค์กร

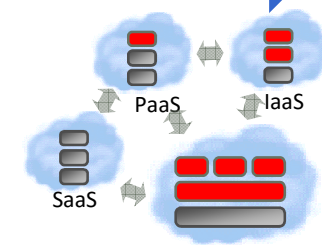
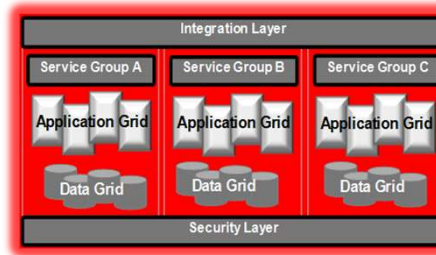
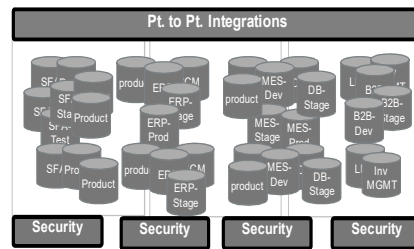
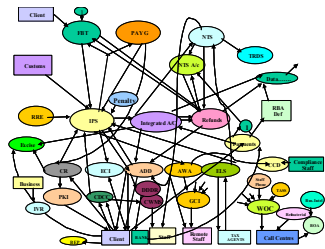

- ต่างคนต่างทำ แล้วมาเชื่อมกันทีหลัง
- ระบบงานกระจาย กระจาย เชื่อมต่อกัน ขาดมาตรฐาน
- เปลี่ยนแปลงยาก
- ขยายระบบยาก
- ใช้เวลามากในการจัดการ และแก้ปัญหา
- มีความเสี่ยงสูง

- จัดกลุ่มกระบวนการทำงาน และทรัพยากรไอที
- มีมาตรฐานในการรับส่งข้อมูล
- ประหยัดค่าใช้จ่ายด้าน SW License และ support
- ลดต้นทุนด้าน IT project time/costs/risks

- ตัดกระบวนการทำงานที่ซ้ำซ้อน
- ลดทรัพยากรทางไอทีที่ไม่จำเป็น
- ผลิตบริการด้านไอทีได้เร็วขึ้น
- เพิ่มความปลอดภัยด้านไอที

- แบ่งกลุ่มบริการทางด้านไอทีโดยมุ่งการต่อยอดบริการใหม่ๆ ให้เร็วที่สุด
- ผลิตบริการได้เร็วและปลอดภัย
- การวางแผนทาง IT ทำควบคู่ไปกับการวางแผนทางธุรกิจ
- เจ้าหน้าที่ไอทีทำงานได้เต็มประสิทธิภาพ

Enterprise Architecture Maturity Model

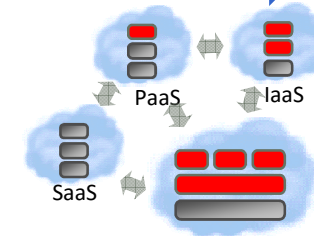
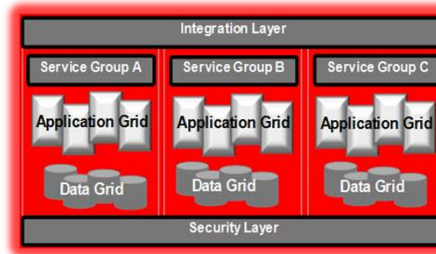
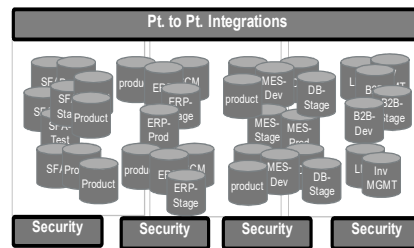
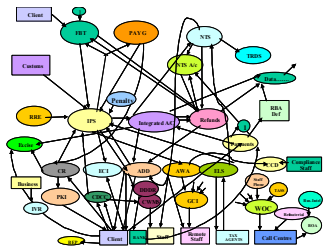

- ต่างคนต่างทำ แล้วมาเชื่อมกันทีหลัง
- ระบบงานกระจาย กระจาย เชื่อมต่อกัน ขาดมาตรฐาน
- เปลี่ยนแปลงยาก
- ขยายระบบยาก
- ใช้เวลามากในการจัดการ และแก้ปัญหา
- มีความเสี่ยงสูง

- จัดกลุ่มกระบวนการทำงาน และทรัพยากรไอที
- มีมาตรฐานในการรับส่งข้อมูล
- ประหยัดค่าใช้จ่ายด้าน SW License และ support
- ลดต้นทุนด้าน IT project time/costs/risks

- ตัดกระบวนการทำงานที่ซ้ำซ้อน
- ลดทรัพยากรทางไอทีที่ไม่จำเป็น
- ผลิตรบริการด้านไอทีได้เร็วขึ้น
- เพิ่มความปลอดภัยด้านไอที

- แบ่งกลุ่มบริการทางด้านไอทีโดยมุ่งการต่อยอดบริการใหม่ๆ ให้เร็วที่สุด
- ผลิตรบริการได้เร็วและปลอดภัย
- การวางแผนทาง IT ทำควบคู่ไปกับการวางแผนทางธุรกิจ
- เจ้าหน้าที่ไอทีทำงานได้เต็มประสิทธิภาพ

Enterprise Architecture Maturity – Details

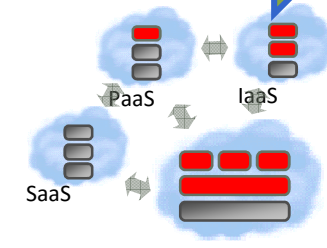
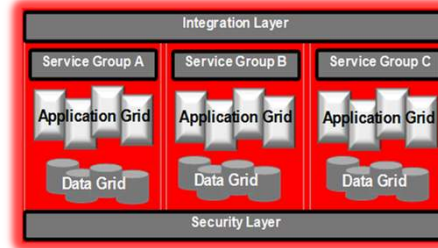
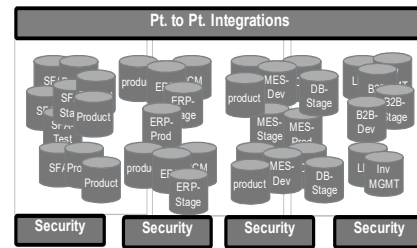
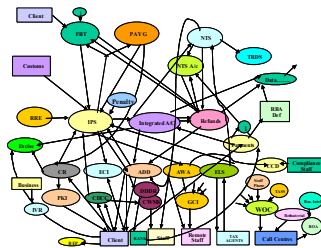

- Local IT silos
- Peak load sized
- Difficult to scale
- Difficult to change
- Expensive to manage
- Complexity driven risk

- Standardized interfaces/systems
- Lower license and support costs
- Increased utilization of IT skills
- Reduced IT project time/costs/risks

- Pools of resources
- Consolidated
- Better productivity
- Higher QoS
- Improved IT agility
- Improved security and management

- Rapid provisioning
- Lower costs
- IT as a “Business”
- Faster project turnaround
- Greater focus on business

Enterprise Architecture Maturity Model

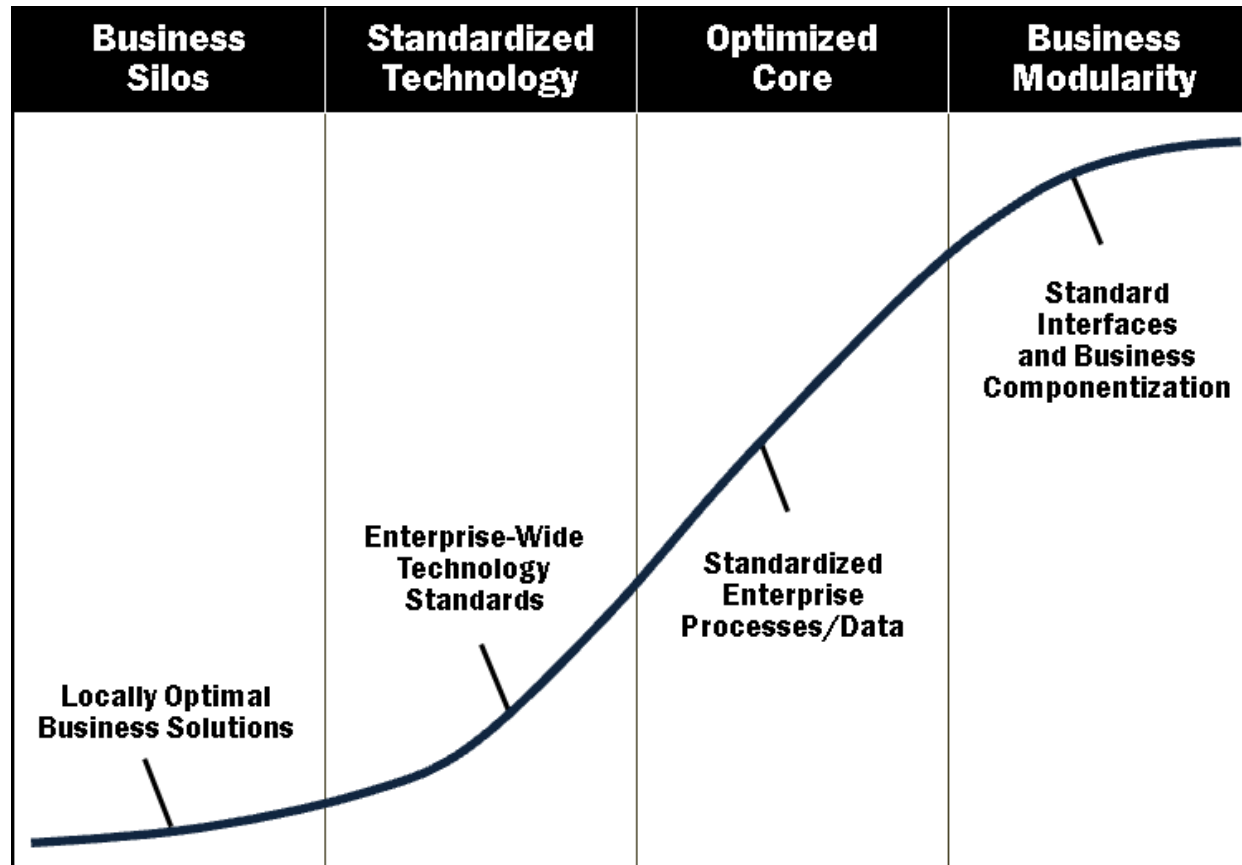

Center for Information Center Systems Research (CISR)

2009 MIT Sloan CISR – Ross

Source: *Enterprise Architecture as Strategy: Creating a Foundation for Business Execution*, J. Ross, P. Weill, D. Robertson, HBS Press, 2006

Enterprise Architecture Maturity Model

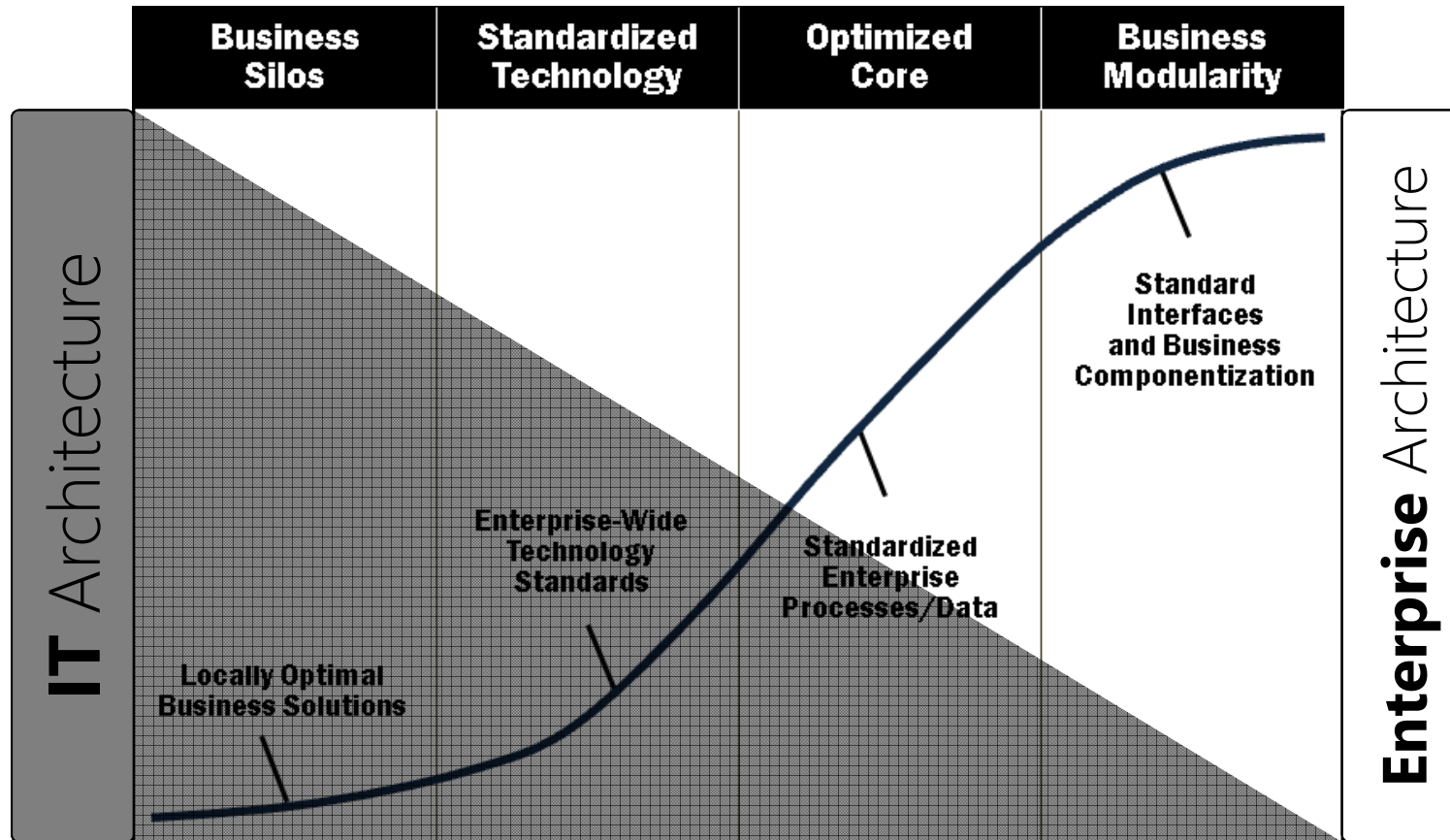

Center for Information Center Systems Research (CISR)

2009 MIT Sloan CISR – Ross

Source: *Enterprise Architecture as Strategy: Creating a Foundation for Business Execution*, J. Ross, P. Weill, D. Robertson, HBS Press, 2006

Enterprise Architecture Maturity Model

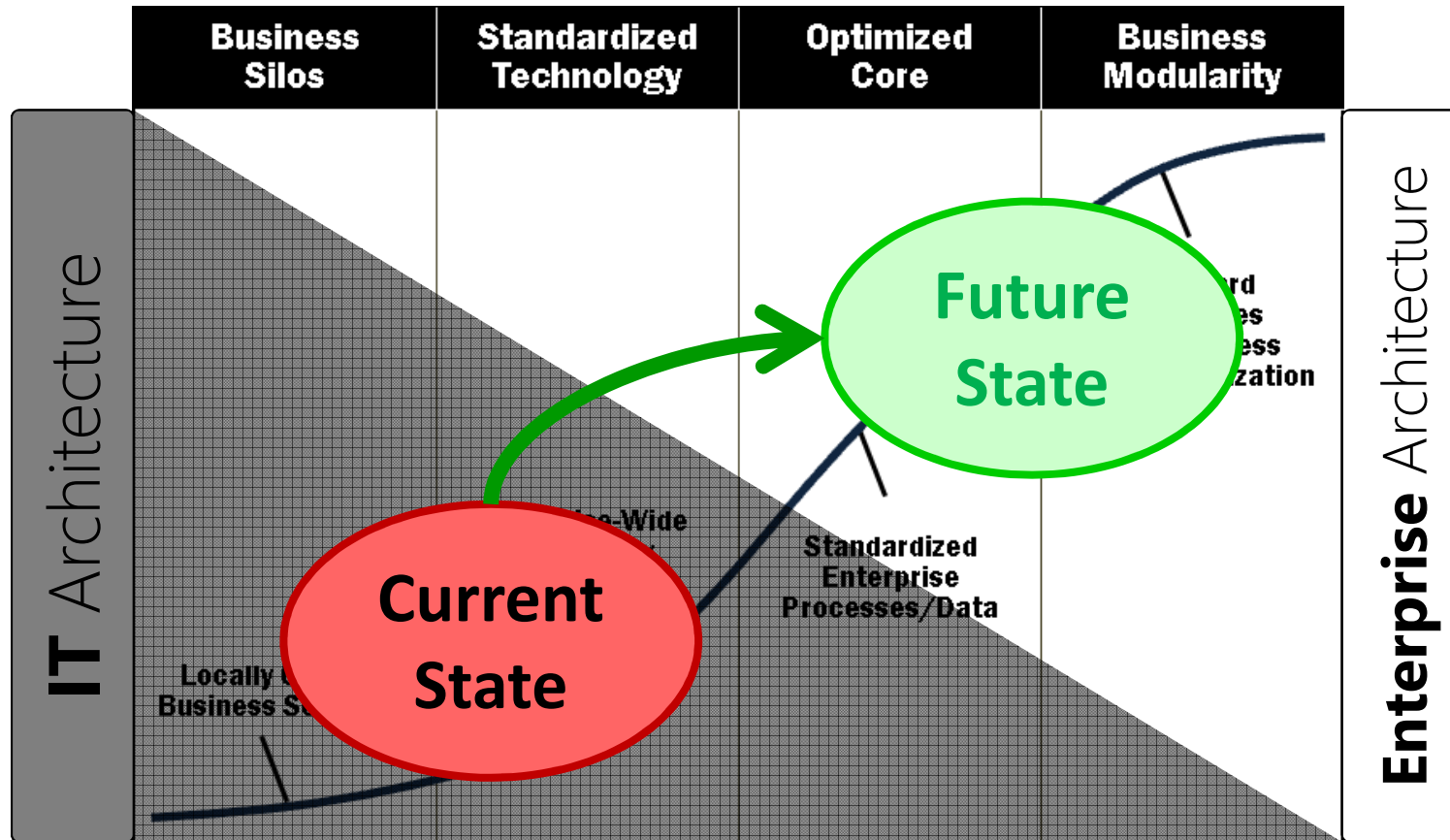

Center for Information Center Systems Research (CISR)

2009 MIT Sloan CISR – Ross

Source: *Enterprise Architecture as Strategy: Creating a Foundation for Business Execution*, J. Ross, P. Weill, D. Robertson, HBS Press, 2006

Building Enterprise Architecture

There are many of related standards/guidelines

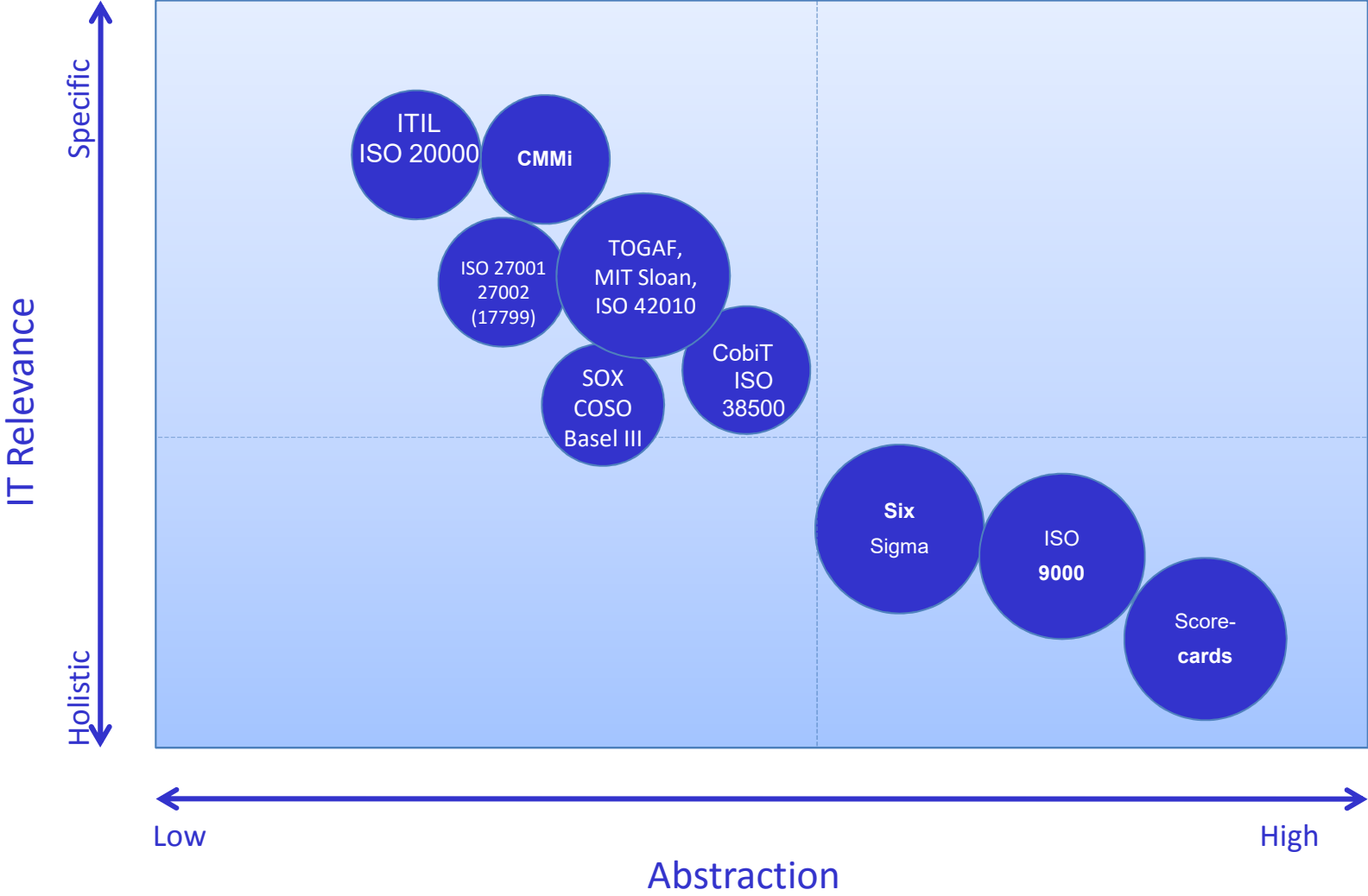



















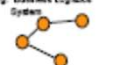





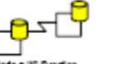





Building Enterprise Architecture

The Digital Transformation Guideline

1. Select program or project to start (NOT high risk) supported by C-Level
2. Establish Virtual Team maintain standard architecture development method
3. Acquire and Maintain Knowledge of Enterprise Architecture Development with change and feed back communication system
4. Create architecture reference based on current deployments
5. Develop new architecture layered model from current deployment with business alignment and operation life cycle consideration
6. Replicate to new program or project development

Zachman Framework

- Zachman developed a structure or framework for defining and capturing an architecture
- This framework provides for 6 perspectives or “windows” from which to view the enterprise.

	DATA <i>#What</i>	FUNCTION <i>How</i>	NETWORK <i>#Where</i>	PEOPLE <i>#Who</i>	TIME <i>#When</i>	MOTIVATION <i>#Why</i>	
SCOPE (CONTEXTUAL)	List of Things important to the Business 	List of Processes the Business Performs 	List of Locations in which the Business Operates 	List of Organizations important to the Business 	List of Events Significant to the Business 	List of Business Goals/Strat 	SCOPE (CONTEXTUAL)
<i>Planner</i>	Entity = Class of Business Thing	Function = Class of Business Process	Node = Major Business Location	People = Major Organizations	Time = Major Business Event	End/Mean = Major Bus. Goal/Critical Success Factor	<i>Planner</i>
ENTERPRISE MODEL (CONCEPTUAL)	e.g. Semantic Model 	e.g. Business Process Model 	e.g. Business Logistics System 	e.g. Work Flow Model 	e.g. Master Schedule 	e.g. Business Plan 	ENTERPRISE MODEL (CONCEPTUAL)
<i>Owner</i>	Ent = Business Entity Rel = Business Relationship	Proc = Business Process IO = Business Resources	Node = Business Location Link = Business Linkage	People = Organization Unit Work = Work Product	Time = Business Event Cycle = Business Cycle	Ent = Business Objective Means = Business Strategy	<i>Owner</i>
SYSTEM MODEL (LOGICAL)	e.g. Logical Data Model 	e.g. Application Architecture 	e.g. Distributed System Architecture 	e.g. Human Interface Architecture 	e.g. Processing Structure 	e.g. Business Rule Model 	SYSTEM MODEL (LOGICAL)
<i>Designer</i>	Ent = Data Entity Rel = Data Relationship	Proc = Application Function IO = User Interface	Node = OS Function (Processor, Storage, etc) Link = Link Characteristics	People = Role Work = Deliverable	Time = System Event Cycle = Processing Cycle	Ent = Structural Assertion Means = Action Assertion	<i>Designer</i>
TECHNOLOGY MODEL (PHYSICAL)	e.g. Physical Data Model 	e.g. System Design 	e.g. Technology Architecture 	e.g. Presentation Architecture 	e.g. Control Structure 	e.g. Rule Design 	TECHNOLOGY MODEL (PHYSICAL)
<i>Builder</i>	Ent = Segment/Table/etc. Rel = Pointer/Key/etc.	Proc = Computer Function IO = Data Elements/Sets	Node = Hardware/System Software Link = Link Specifications	People = User Work = Screen Format	Time = Execution Cycle = Component Cycle	Ent = Condition Means = Action	<i>Builder</i>
DETAILED REPRESENTATIONS (OUT-OF-CONTEXT)	e.g. Data Definition 	e.g. Program 	e.g. Network Architecture 	e.g. Security Architecture 	e.g. Timing Definition 	e.g. Rule Specification 	DETAILED REPRESENTATIONS (OUT-OF-CONTEXT)
<i>Sub-Contractor</i>	Ent = Item Rel = Address	Proc = Language/Ent IO = Control Block	Node = Apparatus Link = Protocol	People = Identity Work = Job	Time = Interval Cycle = Machine Cycle	Ent = Sub-condition Means = Step	<i>Sub-Contractor</i>
FUNCTIONING ENTERPRISE	e.g. DATA	e.g. FUNCTION	e.g. NETWORK	e.g. ORGANIZATION	e.g. SCHEDULE	e.g. STRATEGY	FUNCTIONING ENTERPRISE

TOGAF Architecture Development Method

The ADM method consists of eight main phases. As preliminary work, the enterprise architecture framework and architecture principles are fixed for the effort. In the following, a short description of the phases.

A. Architecture vision is the analysis phase of EA project. The project is organized; the scope and domain requirements and constraints are stated. Business scenarios can be used for this.

B. In the Business architecture phase, the current baseline architecture is stated, target architecture is designed and a gap analysis between the two takes place.

C. Information systems architecture consists of the parts Data and Applications. For Data architecture, the types and sources of data needed in the enterprise are defined and a data model is created. A gap analysis is conducted and data model is compared with the business architecture. As to the applications, the applications needed to meet the specified business requirements and data model are turned into an applications architecture and are checked back with the business architecture.

D. For Technology architecture, the previous phases deliver inputs. In this phase, a baseline architecture is stated, and the target technology architecture is designed.

E. Opportunities and solutions is the evaluation phase, where the solutions are selected.

F. Migration planning is the point for checking dependencies in the environment and preparing for implementation of the target architecture.

G. Implementation and Governance is about the administration of implementation and deployment phase of the development project.

H. Architecture change management is the maintenance phase. A new baseline is created and changes in business environment are monitored as well as new technology opportunities.

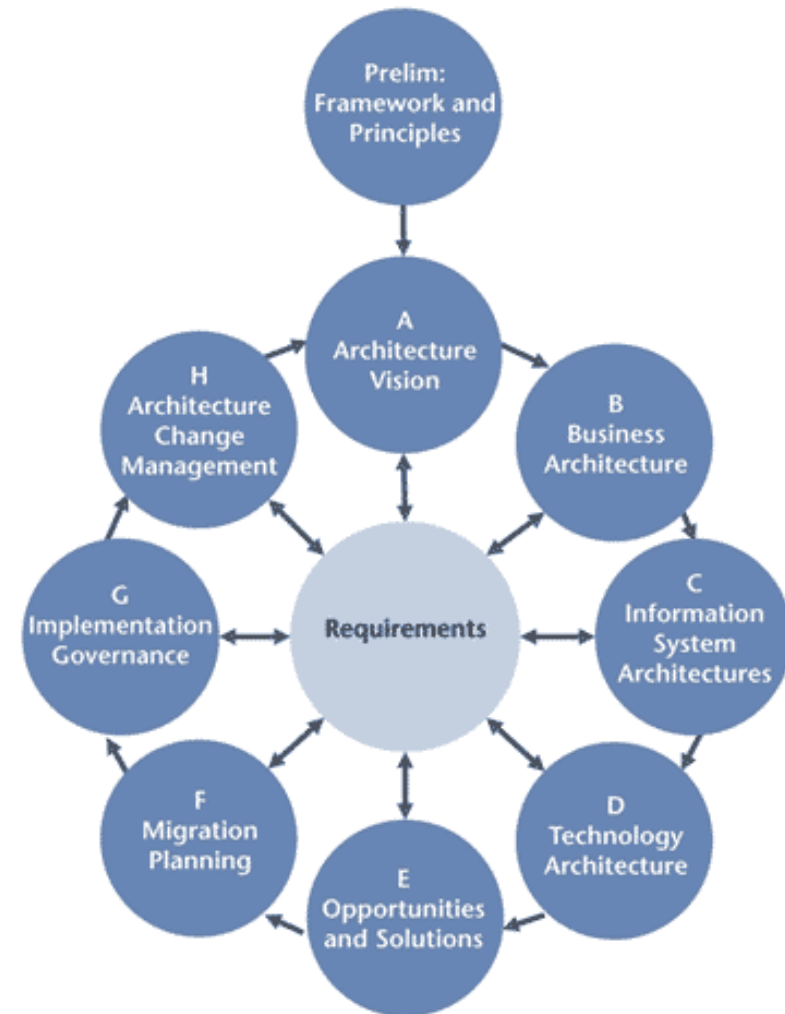

www.opengroup.org

Business Architecture & IT Architecture

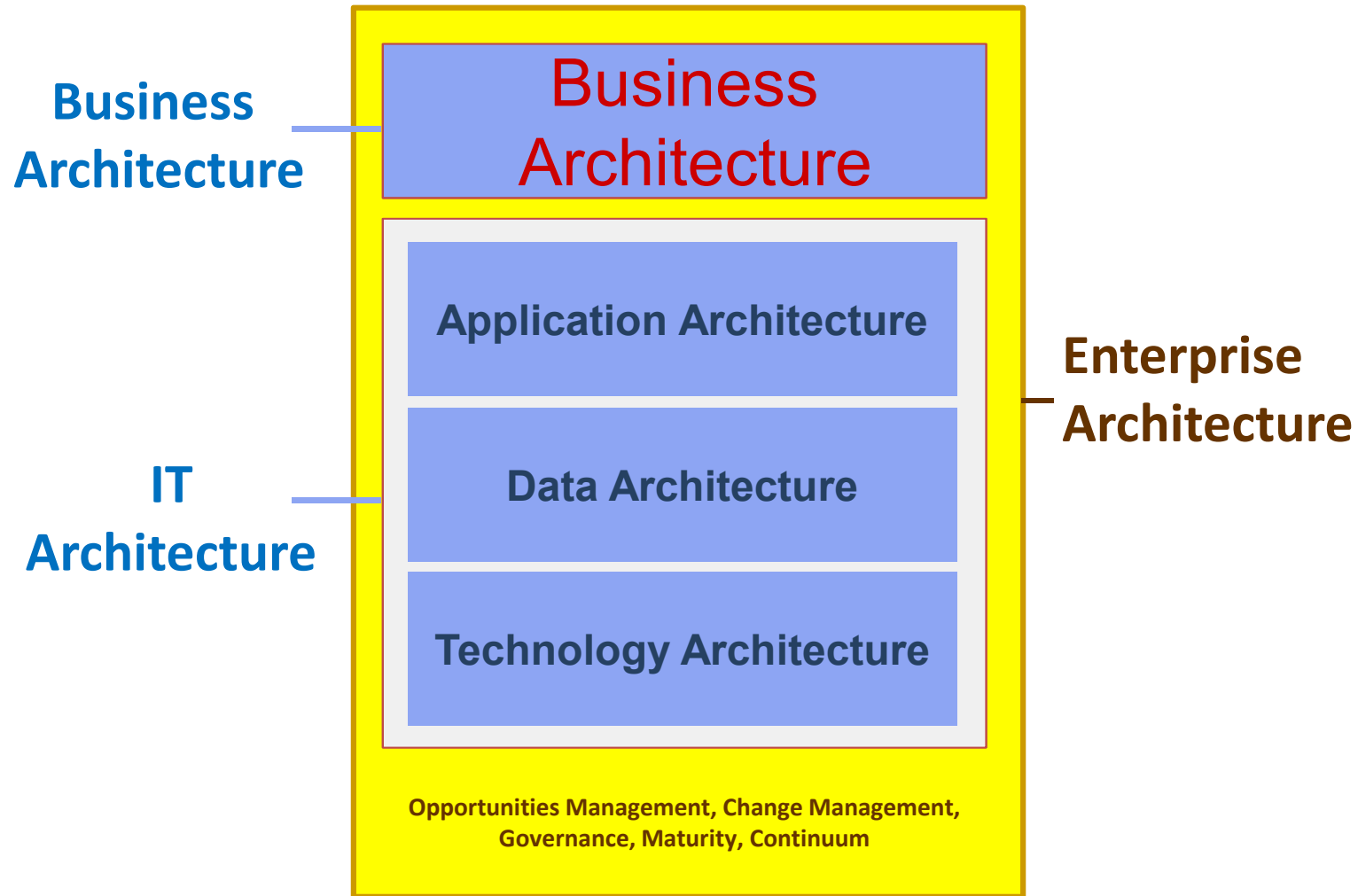

The Enterprise Reference Model

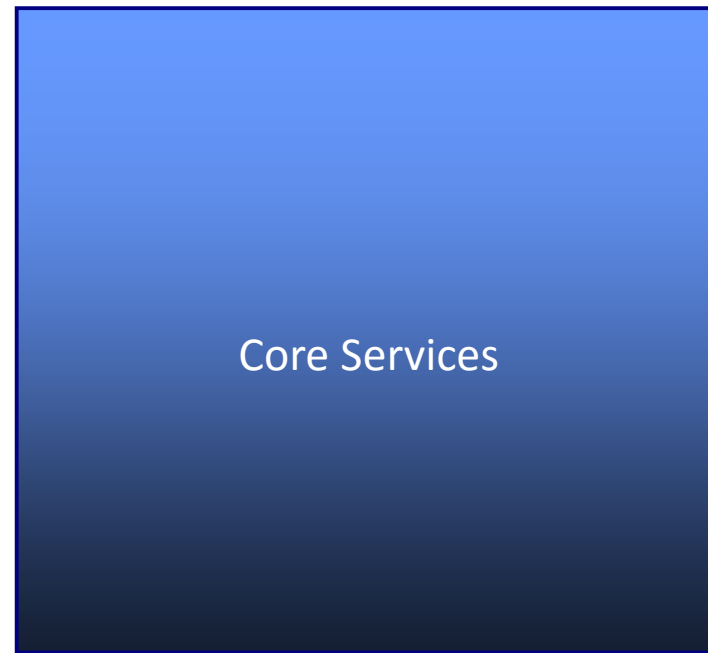

The Enterprise Reference Model

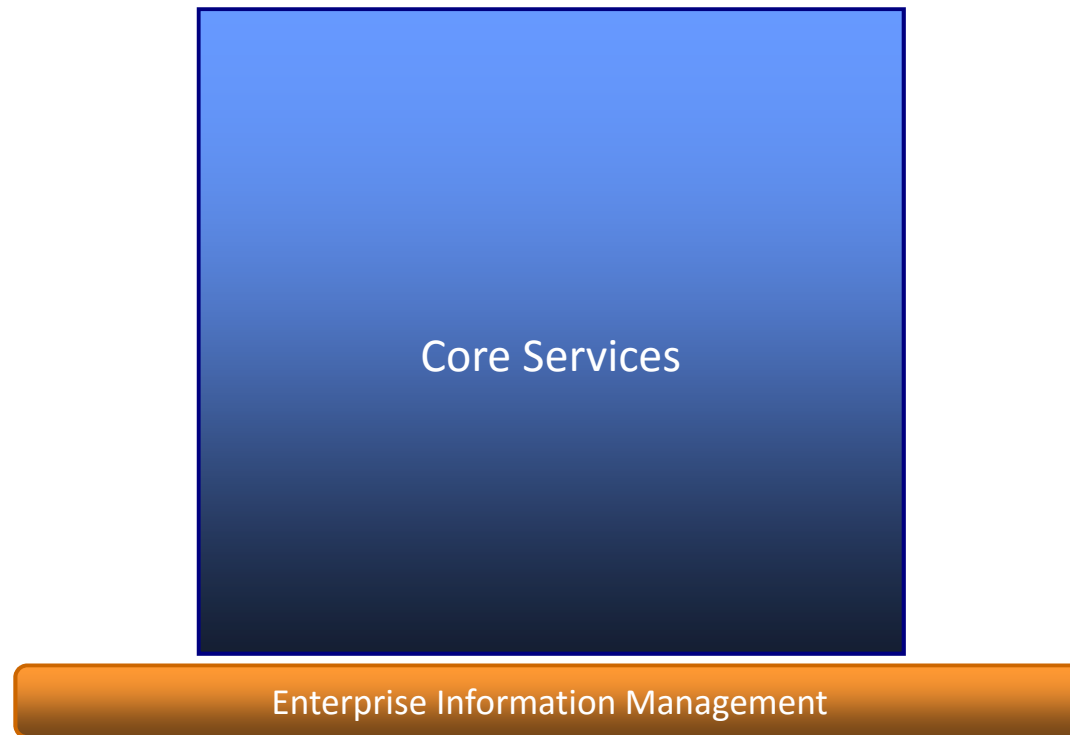

The Enterprise Reference Model

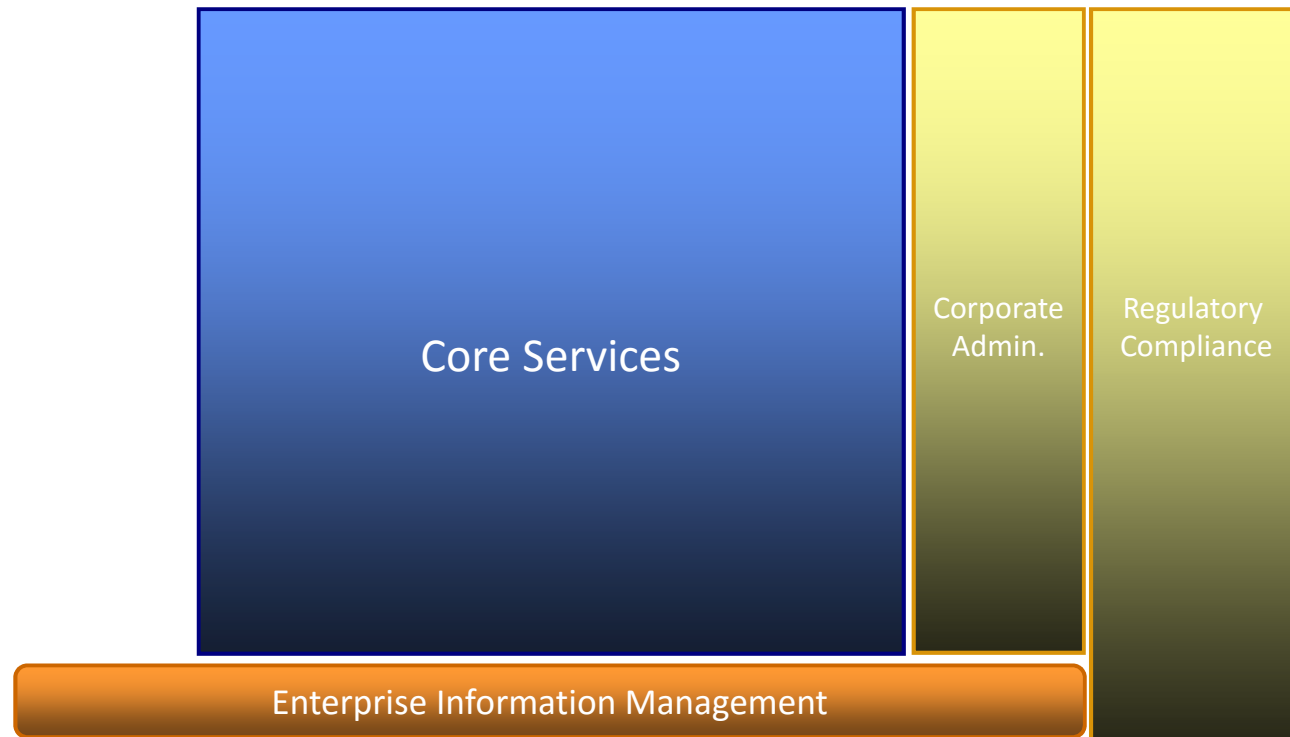

The Enterprise Reference Model

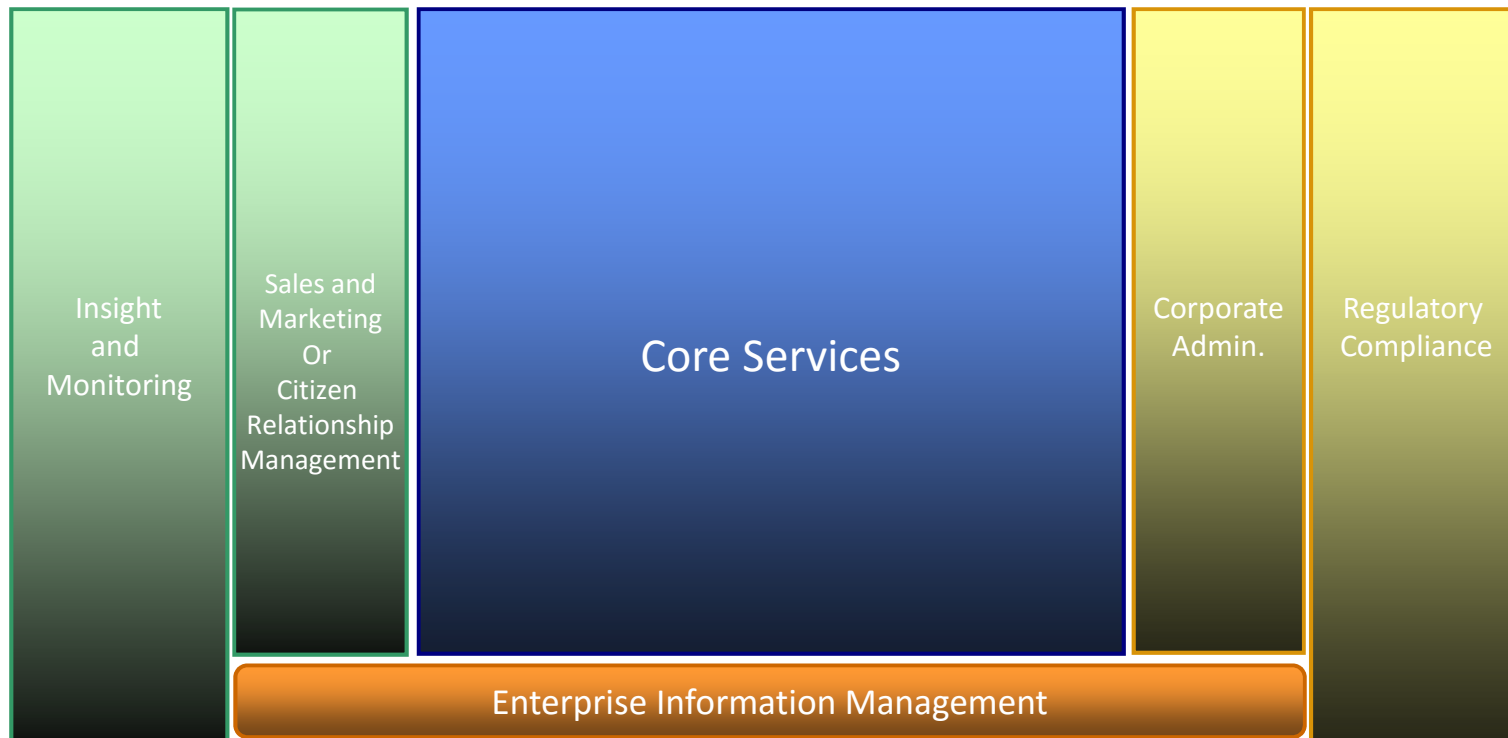

The Enterprise Reference Model

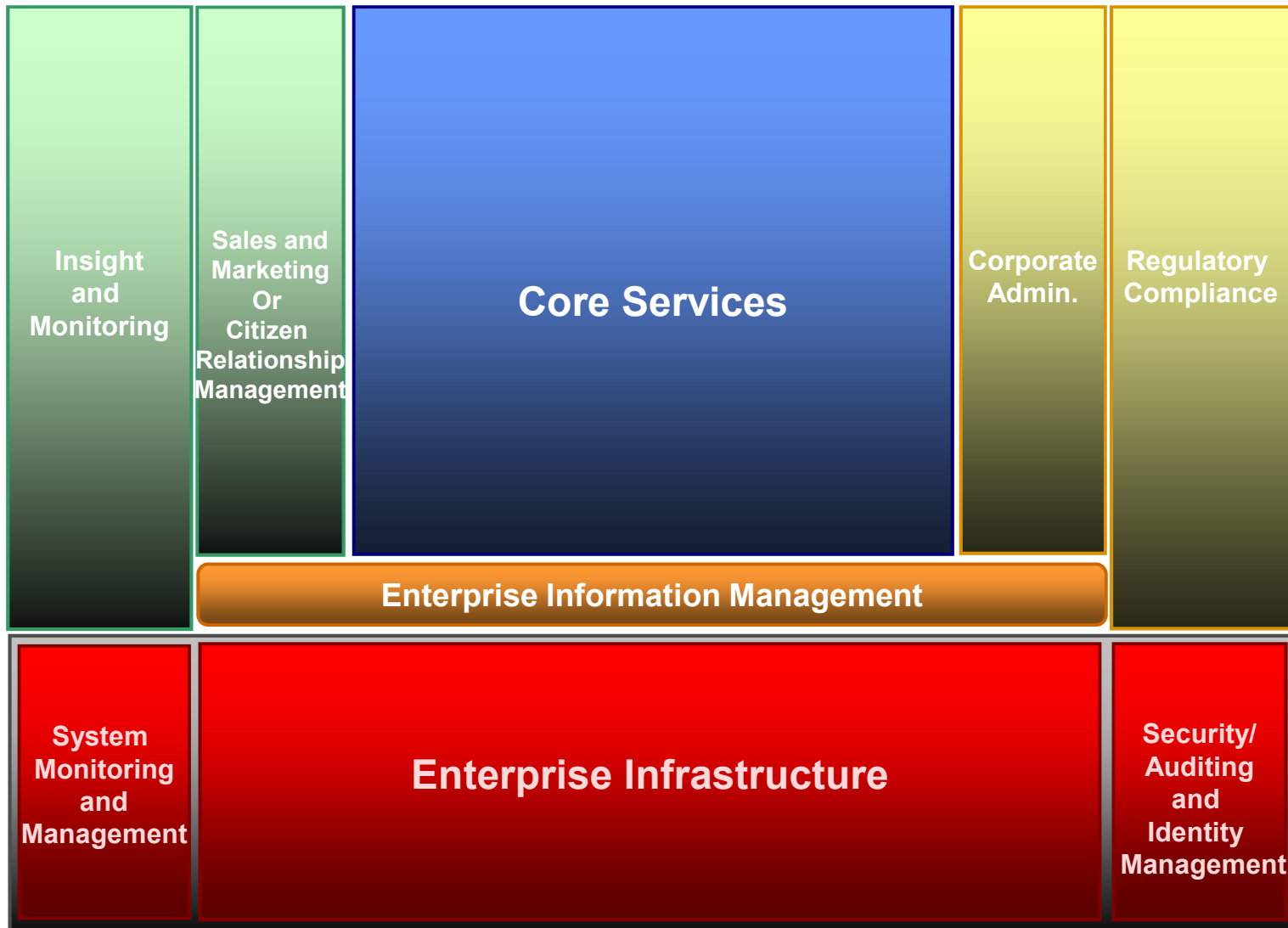

The Enterprise Reference Model

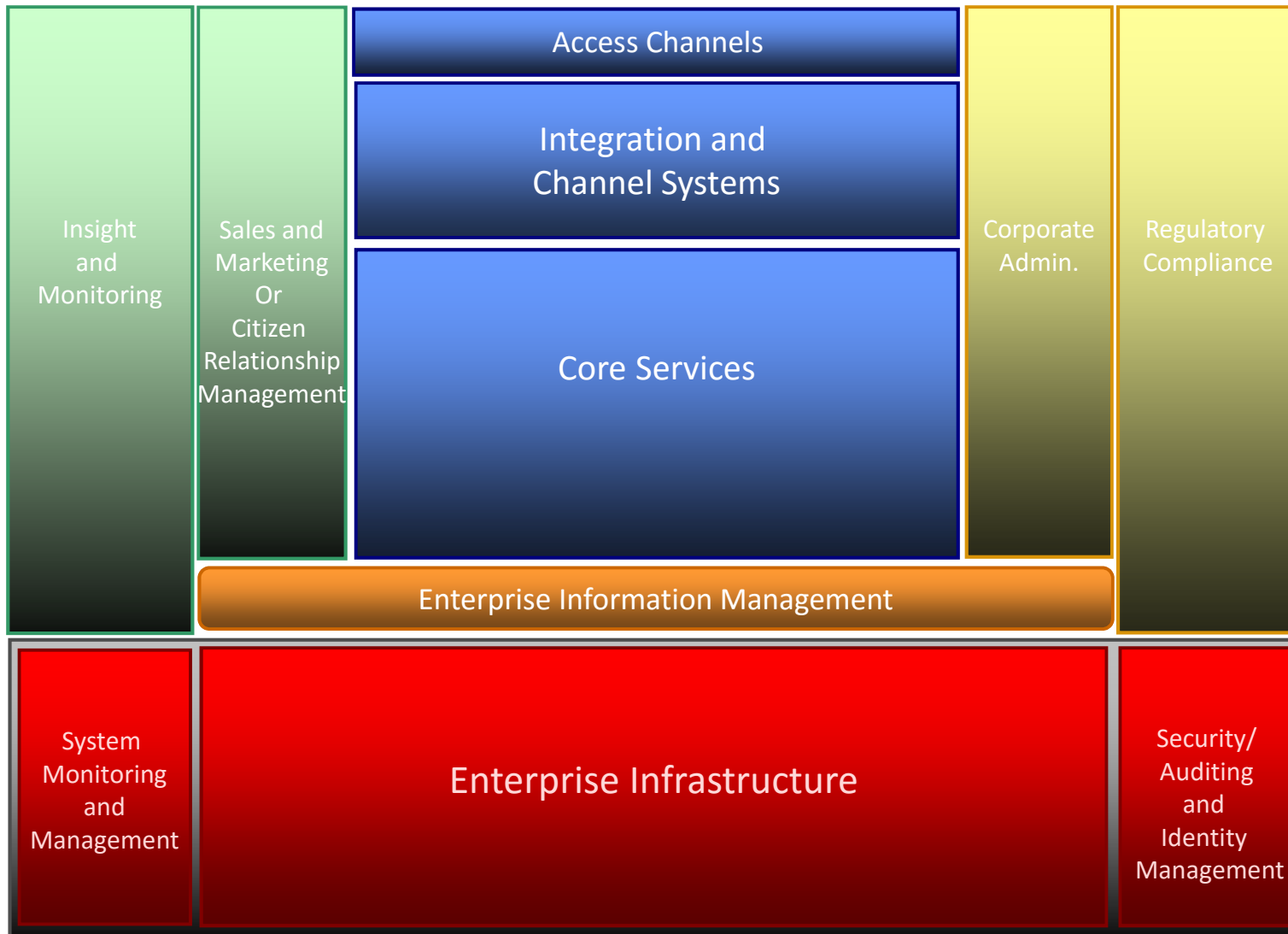

The Enterprise Reference Model

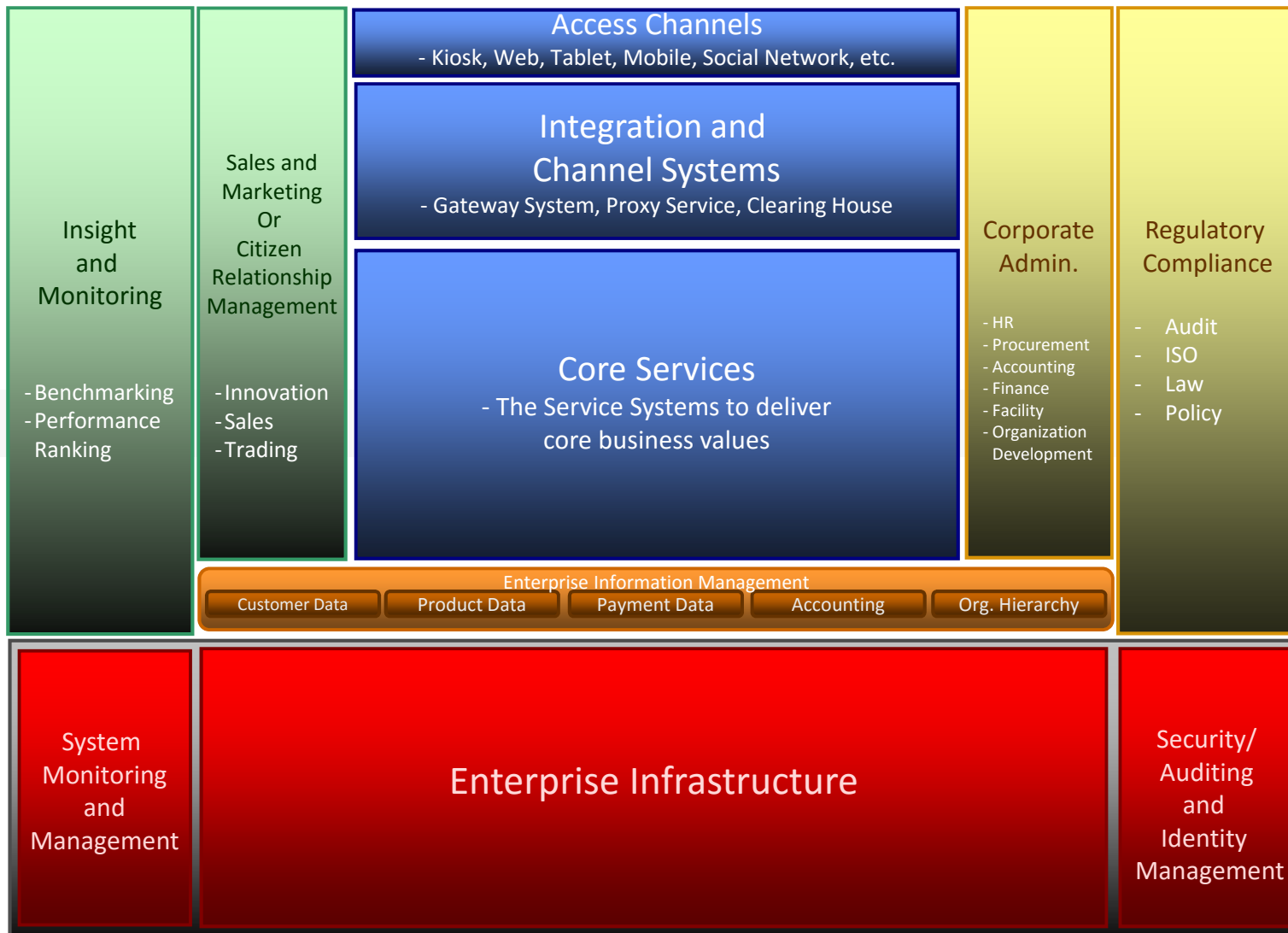

The Enterprise Reference Model

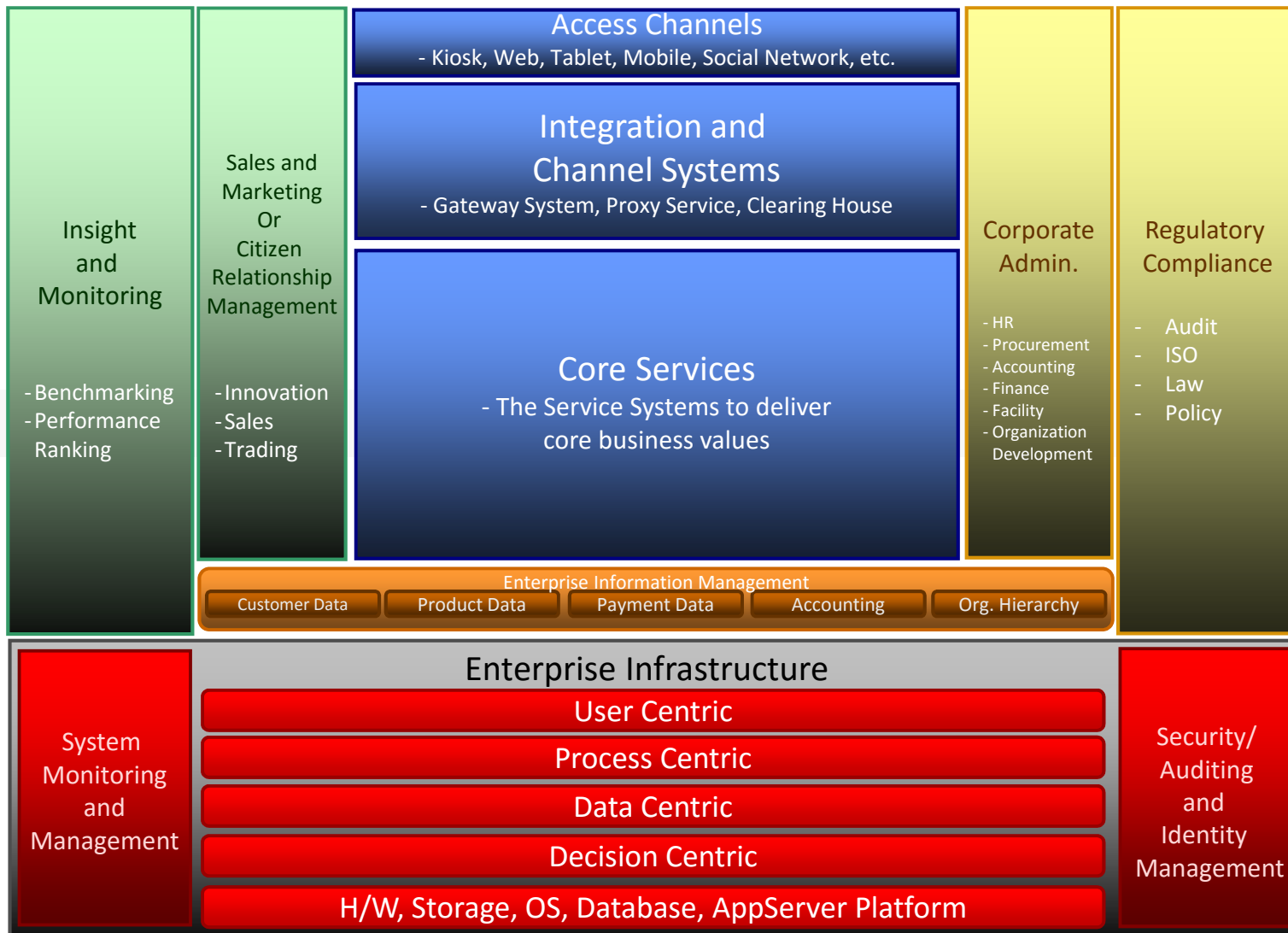

Enterprise Reference Model (ERM)

ERM ช่วยทำให้การมองภาพความสอดคล้องระหว่าง Business และ IT ในระดับ High Level เพื่อ:-

1. ช่วยทำให้การมอง IT จากภาพของธุรกิจ
2. ช่วยทำให้มองเห็นบริการและกระบวนการทำงานทางธุรกิจได้อย่างครอบคลุมและเป็นระบบ
3. ช่วยทำให้มองเห็นความสอดคล้องระหว่าง Business กับ IT ได้ในระดับ Strategic View
4. เป็นจุดเริ่มต้นของการทำรายละเอียดในระยะต่อไป

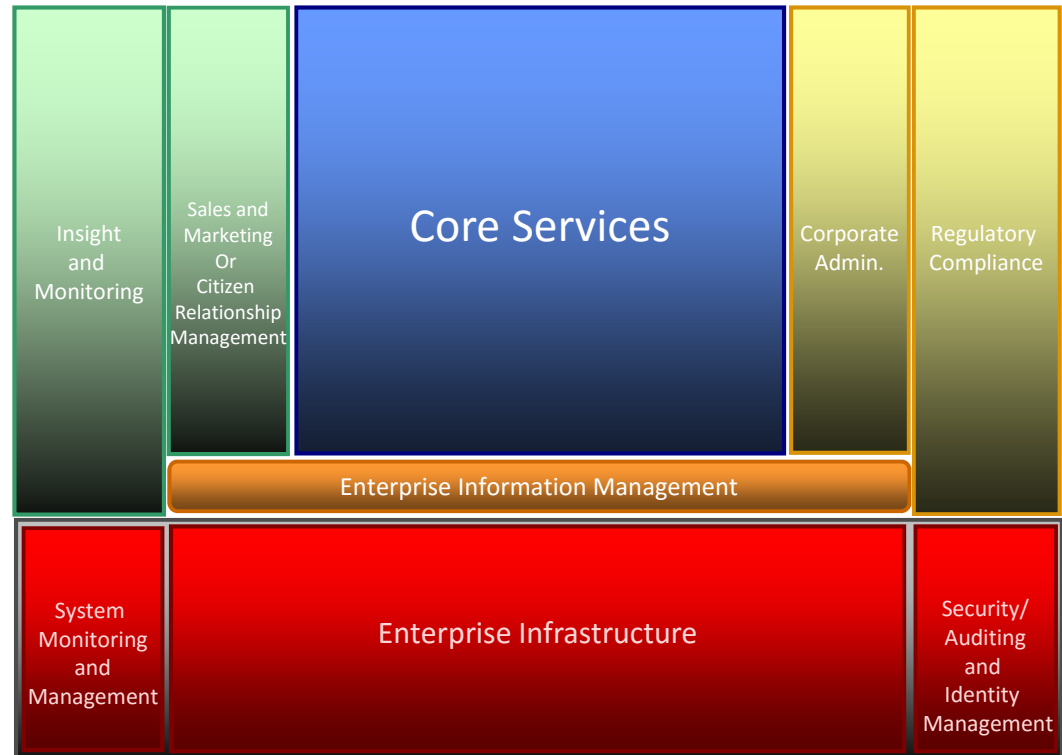

Government Reference Model

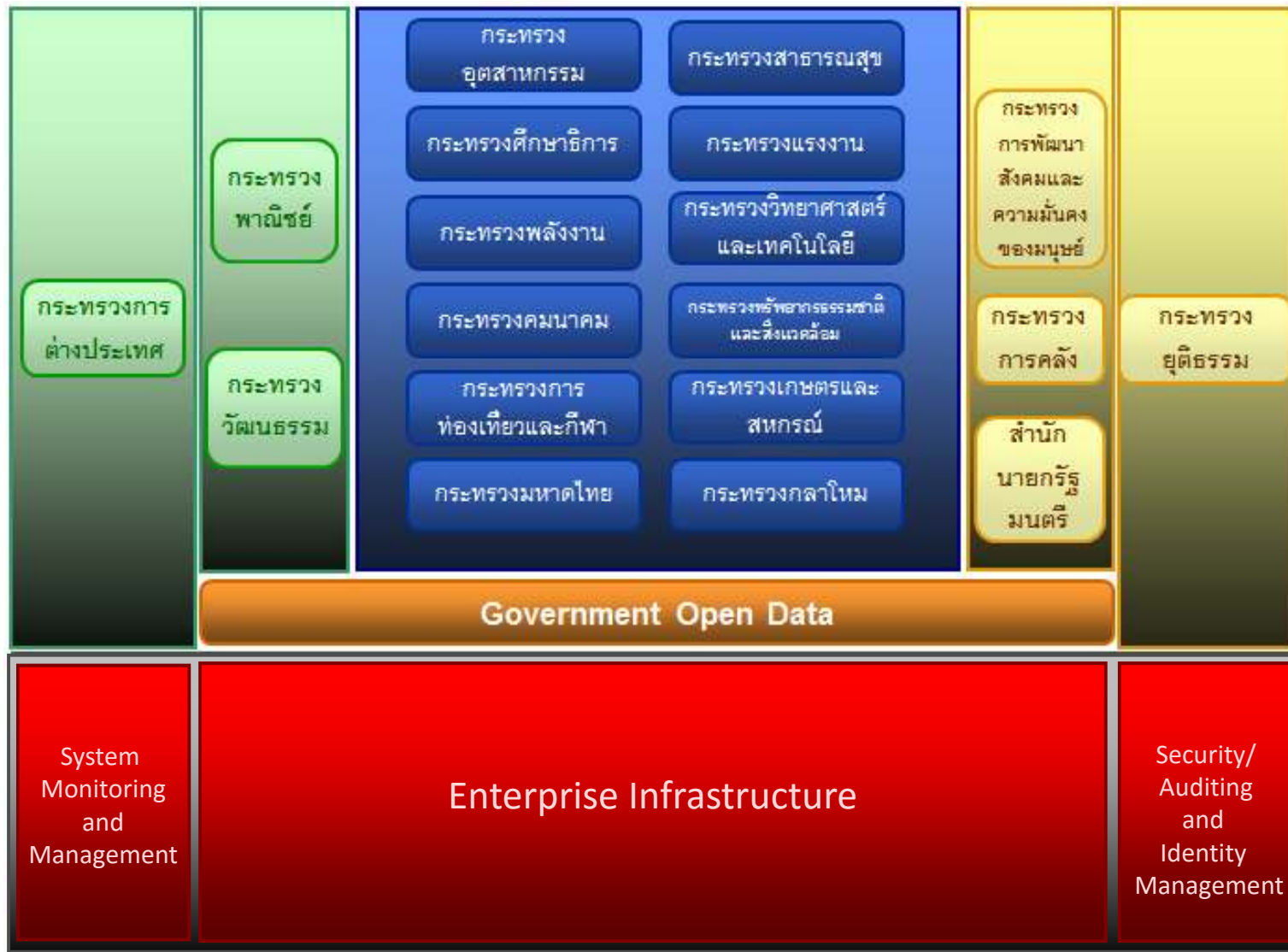

Sample Enterprise Reference Model

Insight & Monitoring # Industry performance # Fund performance # In/out flow # Investment research # Investment information	Marketing / CRM # iBanking # mBanking # Branch channel # IVR # Call center # Wealth planning tool	Access Channels BBL Branch / Web / Mobile	Corporate Admin. IT / Fund accounting / Company accounting / HR / Procurement / Compliance / Legal	Regulatory / Compliance BOT / SEC / Internal Audit / BBL
		Integration & Channel Systems BBL P9000 / SET / ThaiBMA / Brokers / Trustees		
		Core Systems Fund Accounting System / Investment allocation system / Customer information system # จัดตั้งและบริหารกองทุนตามนโยบายการลงทุนเพื่อ ผลตอบแทนที่เหมาะสมภายใต้ความเสี่ยงที่ยอมรับได้ # เผยแพร่ความรู้เพื่อส่งเสริมการวางแผนการลงทุน		
Enterprise Information Management Customer data / Investment information / Fund accounting / Company accounting / Employee info.				
Enterprise Infrastructure				
# Fund Allocation System # Fund accounting system # Stock ordering	User Centric: Windows XP / Windows 7 / Web based application Process Centric: HRMS Data Centric: Word / Excel / Text / CSV Decision Centric: Bloomberg / Bisnews H/W: Vmware / SAN / NAS / IP Phone / Windows 2003, 2008, 2013 / Oracle / SQL / Sybase / Pervasive			# AD # Firewall # Anti-virus

Insight and Monitoring : MIS	Sales and Marketing or CRM : Call Center / Product Reports / Web Conference	Access Channel : Branch / Partner's Counter	Corp Admin HR/ ERP : Account, Fixed Asset, Procurement Inventory/Budgeting/ ประกาศ คำสั่ง / Facilities Reservation	Regulatory/Compliance : BOT, AMLO, ปปง, สศร, ICT (กฎหมายภาคธุรกิจ), NCB
		Integration and Channel Systems : Image Cheque Clearing (ICAS) , SWIFT, BAHTNET, NCB, ทะเบียนราษฎร์, บลชี (Web Services)		
		Core Systems : Loan Origination / Loan Process (Fixed Loan, PN, CCF, Leasing&HP, LG, Aval, Trade Finance) / Loan Collection / Collection Center System / Collateral&Insurance / Saving / Fixed Deposit		
Enterprise Information System Customer Data / Loan Data / Payment Data / NPL Data/Dataset / NCB data / Subsidy Data / HR / Accounting				
Enterprise Infrastructure User Centric : Process Centric : Data Centric : Decision Centric :				
Cisco Prime, Solarwind, AppManager, Opmanager	VB6, .NET, Java, Foxpro, ASP.NET HW, Storage, OS, Database, AppServer Platform VMWare / Intel/ SPARC / SAN / Tape Windows / Solaris / Linux MSSQL / Oracle / DB2 Client-Server / .NET / jboss/Tomcat			Security/Auditing/IDM : Active Directory /FW/IPS/Web Filtering/Proxy/Antispam/Antivirus

Insight and Monitoring Performance (Operation Profit)	Sales and Marketing or CRM Sale Forecast/ Design	Access Channels Web , Clients, EDI	Corporate Admin HRM/HRD Web Page Training Evaluate Safety CCTV Finance -ERP -AR,AP,Fix Asset, GL -E-Payment	Regulatory Compliance Internal Audit ISO Environment ISO Document Compliance CKWAY
		Integration and Channel Systems Email , Internet , Proxy		
		Core System Manufacturing (Exhaust,CPM,Air)		
		Enterprise Information Management Customer Data (Part, Term , Price , Discount) Product Design Supplier Data (Part, Term, Price, Discount) Part Information NPL		
			Logistic - Forecast (EDI) - Invoice - DCS - Excise TAX	
			Purchasing	
Enterprise Infrastructure H/W (Server, Network, Storage, UPS, OS) (PC, NotesBook), Web EDI, VM S/W (Database) / E-Application				
Monitoring and Management		Security / Auditing and Identity Management Global JSDX ITGC Proxy/BlueCoat Antivirus		

Insight and Monitoring - KPI - SLA - Call Monitoring	Sales and Marketing - Sales - Procurement - AE	Access Channels Workflow, Web, Mobile, Tablets, etc.	Corporate Admin. -HR -Accounting -Finance -Facility -PMO - Solution Delivery - Technical Support - Network & Infrastructure - Security - Quality Assurance - R&D	Regulatory Compliance -Internal Audit -External Audit -ITIL -Policy
		Integration and Channel Systems Online Gateway, CS Gateway		
		Core Services MM Service, POS&SC Services, CS Services, Ordering Service, Online Service, Warehouse Service, Accounting Service		
		Enterprise Information Management Time Recording Data, SR Data, Incident Data, Problem Data, Hotline Data Product Master Data, Payment Data, Customer Data, Ordering Data, Accounting Data, Warehouse Data		
System Monitoring and Management		Enterprise Infrastructure VB 6.0, Microsoft .NET, Java, Lotus Note Workflow, SAP, Web Services, PPM, etc.		Security/Auditing and Identify Management

Sample Enterprise Reference Model

INSIGHT AND MONITORING - KPI - DASHBOARD	SALES AND MARKETING OR CITIZEN RELATIONSHIP MANAGEMENT - SALES - MARKETING	ACCESS CHANNELS WEB SITE MOBILE	CORPORATE ADMIN - HR - PURCUREMENT - ACCOUNTING - FINANCE - IT (SW / HW) - CPO - QA	REGULATORY COMPLIANCE - POLICY - ISM - ISO	
		INTEGRATION AND CHANNEL SYSTEMS PROXY SERVICE			
		CORE SYSTEMS SALE ELEVATOR & ESCLATOR & MAINTENANCE			
ENTERPRISE INFORMATION MANAGEMENT EMPLOYEE DATA CUSTOMER DATA PRODUCT DATA PAYMENT DATA ACCOUNTING INVENTORY					
SYSTEM MONITORING AND MANAGEMENT	ENTERPRISE INFRASTRUCTURE			SECURITY / AUDITING AND IDENTITY MANAGEMENT PROXY	
	USER CENTRICE (MOCKUP) PHP JSP VB.NET ASP.NET				
	PROCESS CENTRIC MICROSOFT VISIO				
	DATA CENTRIC WEBSERVICE				
	DECISION CENTRIC				
	H/W, STORAGE, OS, DATABASE, APPSERVER PLATFORM AS400, INFORMIX				

Market Share / Rankin	Retail / High Network E-Biz	Access Channels : Internet Trading / Mobile Trading	Corp Admin Finance Settlement Custodian IT Accounting	Compliance & Audit / Risk SEC / SET / BOT / AMLO Regulations
		Integration : SET / SETTrade / TSD / BSB / E - Banking		
		Core Services : Securities Brokerage (Equity & Derivatives)		
		Trading Account / Bank Account Equity / Derivatives / Mutual Fund Settlement Due Date / Clearing Due Date		
OpManager Cisco AAA	User : HiTrade / SBA / Sun Accounting / Efin+ / Straming Process : Front - DGW - Back Data : Trading Transaction Historical / Commission Rate / CL Info Data : Web Service / FTP Decision : Trading Application (Credit Approval) / Decision : Credit Line Adjustment (Risk) / Decision : HR System HP OpenVMS / Linux / Windows / SQL / Informix VB / .NET / Java / VMWare			Credit / Margin Risk Control Active Directory Firewall / IPS Antivirus / Antispam

		Access Channels :web ,Computer Integration and Channel Systems:		
Insight and monitoring	Sales Marketing or Citizen relationship management	Core system	Corporate	Regulatory compliance
performance: software monitor call center	PR เขียนหนังสือ call center	ฐานข้อมูลอาสาสมัคร ฐานข้อมูลผู้บริจาคเงิน ฐานข้อมูลผู้บริจาคดวงตา ฐานข้อมูลผู้บริจาคอวัยวะ	userหน่วยงานย่อย หนังสือขอดำเนินการ	KPI
		customer data product data payment data accounting org. Hierarchy		
System Monitoring	user Centric : PHP XAMPP			Security Auditing and Identity management
	Process Centric : PHP			
	Data Centric : Oracle			
	Decision Centric :			
	HW, Storage, OS, Database, Appserver platform : San Storage			

Insight and Monitoring	Sales and Marketing	Access Channels - Website	Corporate Admin - Procurement - HR - Accounting - Finance - Network & Infrastructure	Regulatory Compliance - Internal Audit - External Audit - Policy
		Integration and Channel Systems Web Gateway		
		Core Systems ให้คำปรึกษาทางด้าน IT - Network & Infrastructure - Business Visualization - Strategic & Planning		
		Enterprise Information Management ข้อมูลลูกค้า ข้อมูลโครงสร้างองค์กร ข้อมูลพนักงาน ข้อมูลธุรกิจคู่ค้า ข้อมูลบัญชีการเงิน		
System Monitoring and Management	Enterprise Infrastructure User Centric			Security/ Auditing and Identity Management
	Process Centric Visio			
	Data Centric Google Cloud			
	Decision Centric			
	H/W, Storage, OS, Database, AppServer Platform File Server			

Sample Enterprise Reference Model

Insight and Monitoring	Sales and Marketing or CRM	Access Channel	Corporate admin	Regulatory Compliance
- Strategy - R&D	- Sales - Marketing	- Web Application Integration and Channel System - Gateway System Core System ผลิตและจำหน่าย มหรืชิกกาเร็ด	- HR - Finance - Budget - Procurement - Accounting - IT	- Audit - Law - Policy
Enterprise Information Management				
- ข้อมูลการรับซื้อใบยา / - ข้อมูล Stock ใบยา / - ข้อมูลเครื่องจักร / - ข้อมูลอะไหล่ - ข้อมูล Stock มหรื / - ข้อมูลลูกค้า / - ข้อมูลการขาย / - ข้อมูลบัญชี				
System Monitoring and Management - CRM Application - Data Warehouse Application - Sale Application	Enterprise Infrastructure		Security/Auditing and Identify Management	
	User Centric - ERP App Process Centric Data Centric - MySQL Database Decision Centric H/W, Storage, OS, DB, AppServer Platform VM Ware Server/San Storage/Network		- Org. Policy - Law - Internal Audit System - KPI Application	

Insight and monitoring	Sales and marketing	Access channels	Corporate Admin	Regulatory Compliance
	Sales	Web, PC Integration and Channel Systems Gateway Core System Passport Passport Queue Booking	HR SE Supporter Helpdesk Front User Research	ICAO MOI Passport Trusting
Enterprise Information Management				
Booking data, HR data, Passport Data, Biometric data,				
System monitoring and Management	Enterprise Infrastructure			Security/Auditing and identify management
	HTML5, Mobile, Java, .Net,			AD
	Web service			
	Glassfish			
	Oracle			
	AQ			

Insight and Monitoring - Requirement - Application Issue/Report - Performance Issue/Report	Sale and Marketing or CRM - Pre sale - Customer account	Access Channels - Telephone - Email - Issue form - Direct Mobile (Optional)	Corporate Admin. - HR - Accounting - Finance - Unit Head (SE/DEV)	Regulatory Compliance - SLA - CMMI - LAW - Policy
	Integration and Channel Systems - Operation center - System Engineer (Optional) - Developer Core Systems - MA service			
	Enterprise Information Management - Customer data - Project/Product data - Issue/Incident data - Payment data - Accounting - Responsibility owner			
ITS department	Enterprise Infrastructure JIRA web application (User/Process/Data/Decision), MA service form system (MA Report) INET cloud, ***OS, Database, AppServer Platform Unknown***		User Identity Management User Authorization Firewall VPN	

Insight and Monitor - KPI งานประกันคุณภาพ - KPI Action Plan - การประเมินผลการปฏิบัติงานประจำปี รายบุคคล	Sales and Marketing Or CRM - งานบริหารวิชาการ	Access Channels - Web, Tablet, Mobile, Internet Access Integration and Channel Systems - ระบบใน Core System ใช้ฐานข้อมูลร่วมกัน - Export/Import Data ผ่านระบบ Core System - GL3D System (Budgeting, Finance, Procurement & Asset, Accounting) - Student Admission System (รับสมัครและประมวลผลสอบคัดเลือก) - Student Registration System (ฝึกสอน, ตารางสอน, ตารางสอน, ลงทะเบียน, ส่งเกรด) - Personal Information System (ระบบบุคลากร)	Corporate Admin. - HR - procurement	Regulatory Compliance - Internal Audit - สดง. - ISO - นโยบายมหาวิทยาลัย - ระเบียบมหาวิทยาลัย - ระบบประกันคุณภาพการศึกษา - การบริหารความเสี่ยง
Enterprise Information Management - Employee Data - Student Data - Procurement Data - Asset Control Data - Finance Data - Accounting Data				
System Monitoring and Management - App: Oracle EM, Network Monitoring System - Manual detection (Log, etc.)	Enterprise Infrastructure - PHP, VB.NET, ASP.NET - Linux, Windows, Oracle, MySQL, Ingres, IIS, Apache		Security/Auditing and Identity Management - Antivirus - Web App Firewall - AD Authentication	

Group Workshop - The Current State

Enterprise Reference Model

Write down your existing enterprise architecture foot print

Team Name: xxx

1. Name, Company, E-mail

2. Name, Company, E-mail

3. Name, Company, E-mail

4. Name, Company, E-mail

Enterprise Reference Model

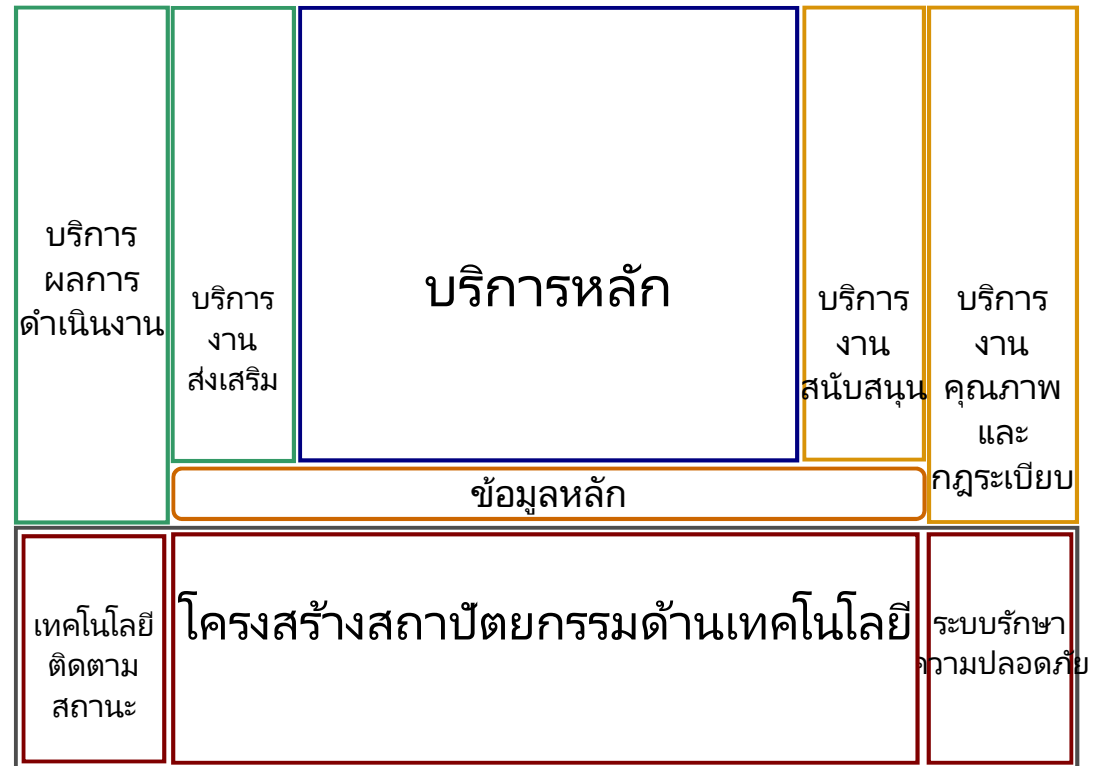

Group Workshop - The Current State Enterprise Reference Model

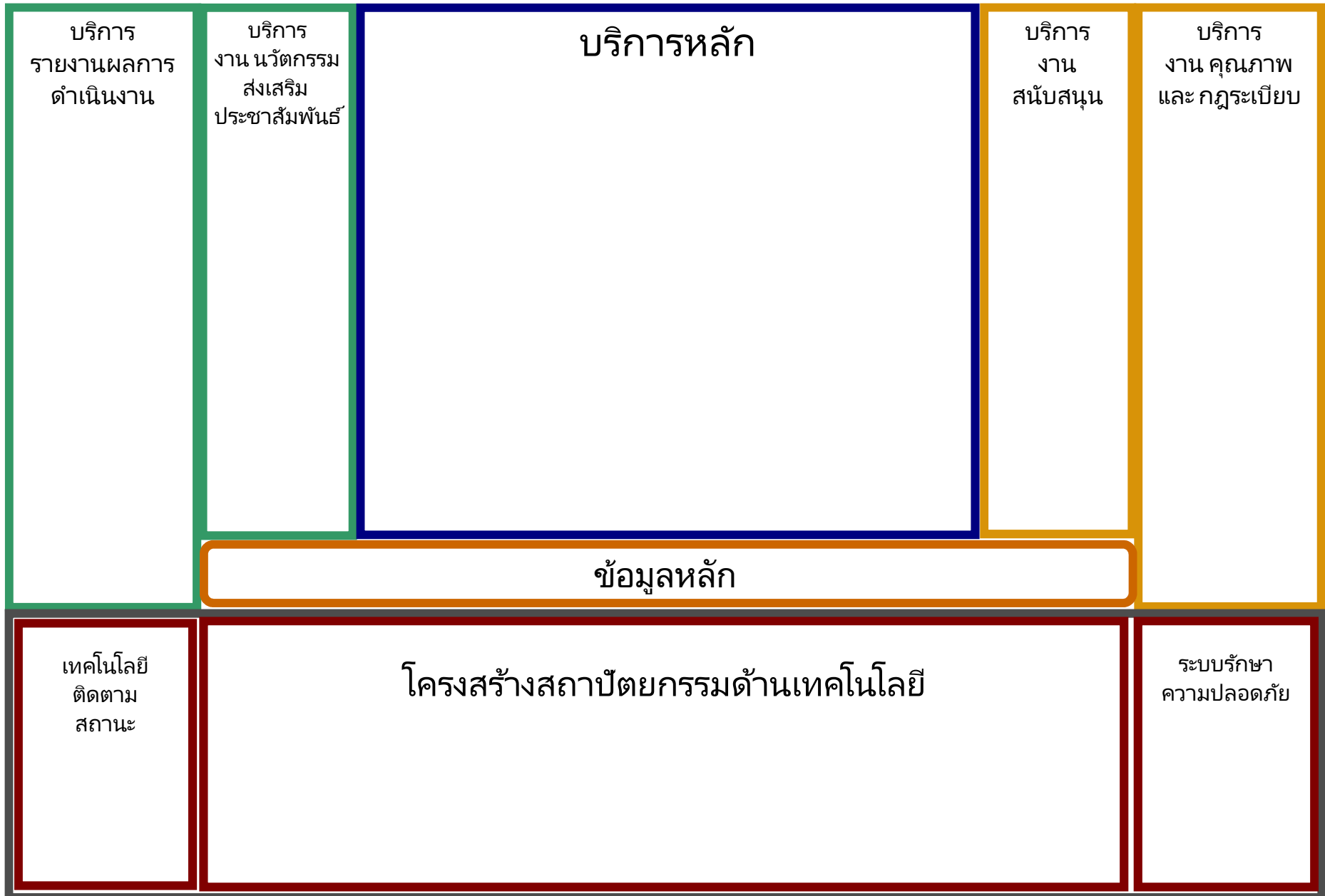

Business Service Analysis Worksheet

Service Name: _____

Key Objectives: 1. _____

Service Owner: _____

- New
- Improve
- Retire

2. _____
 3. _____
 4. _____

Version: _____

Date/Time: _____

Business Function1

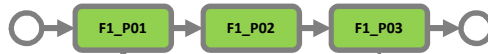

Business Function2

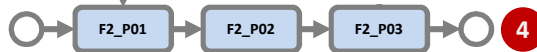

Robotics



Business Check Points, Information

1. _____, _____
2. _____, _____
3. _____, _____
4. _____, _____
5. _____, _____

Key Business Issues: _____

Key Technology Issues: _____

แบบการปรับปรุงบริการในหน่วยงาน

ชื่อบริการ: _____

หน่วยงานที่รับผิดชอบ: _____

Version: _____ Date/Time: _____

เป้าประสงค์:

- ใหม่
- ปรับปรุง
- ยกเลิก

1. _____
2. _____
3. _____
4. _____

หน่วยงานที่ 1

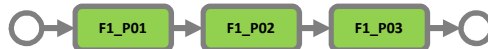

หน่วยงานที่ 2

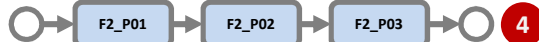

Robotics



จุดติดตามขั้นตอนการทำงาน, สารสนเทศ

1. _____, _____
2. _____, _____
3. _____, _____
4. _____, _____

ประเด็นติดค้างด้าน _____
กระบวนการทำงาน: _____

ประเด็นติดค้างด้าน _____
เทคโนโลยี : _____

Operating Model in Business

“The operating model is an abstraction representation of the necessary level of business process integration and the necessary level of business process standardization”

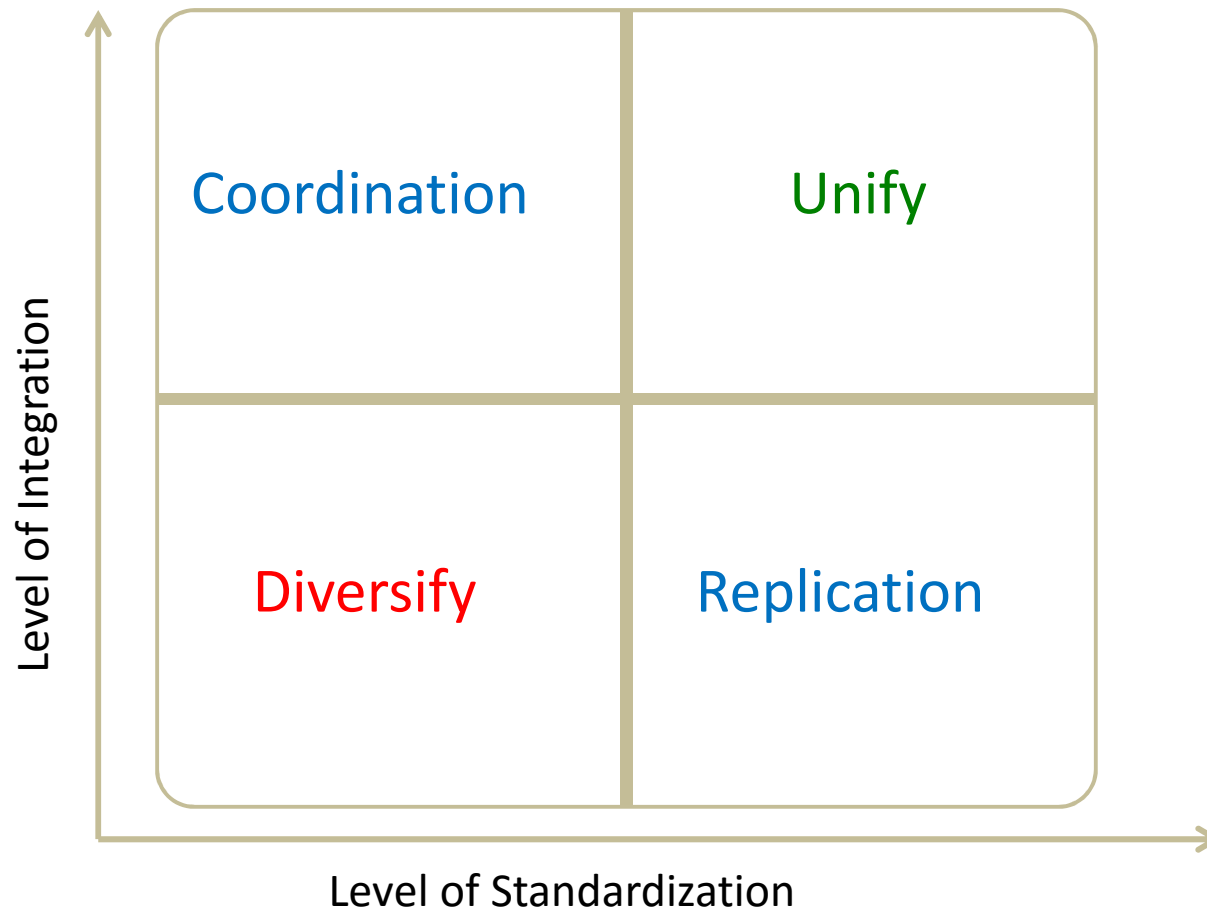

Business Architecture and BPMN

4 phases of business process development

1. Blackboxing phase

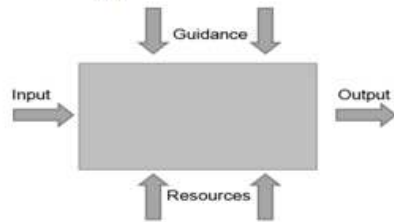

2. Structuring phase

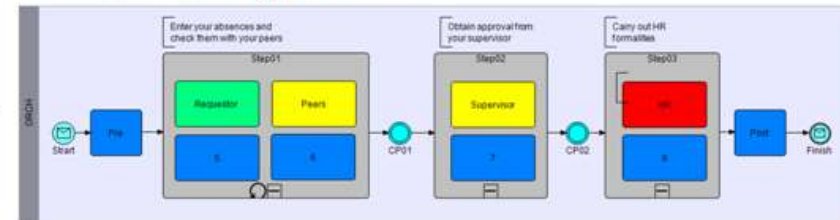

4. Instrumentation phase

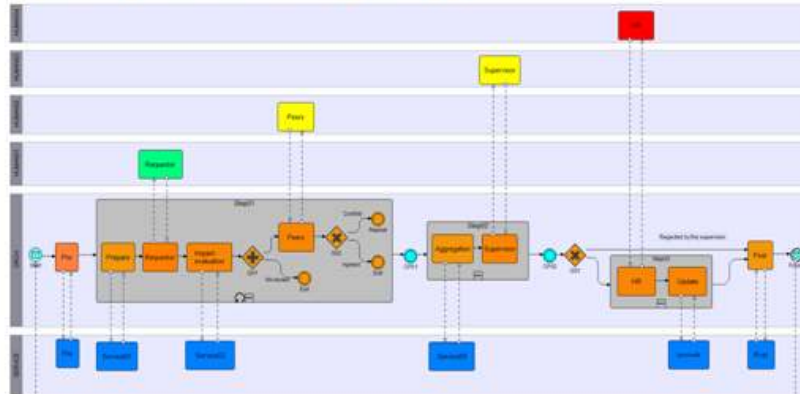

3. Re-construction phase

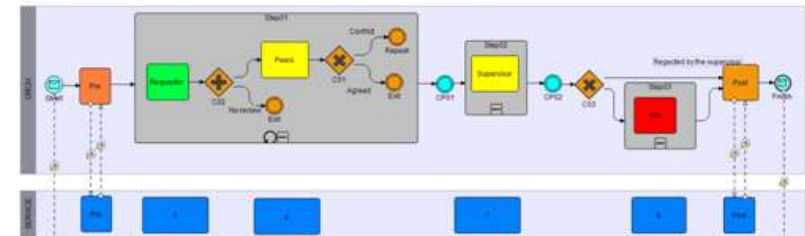

Design Principles

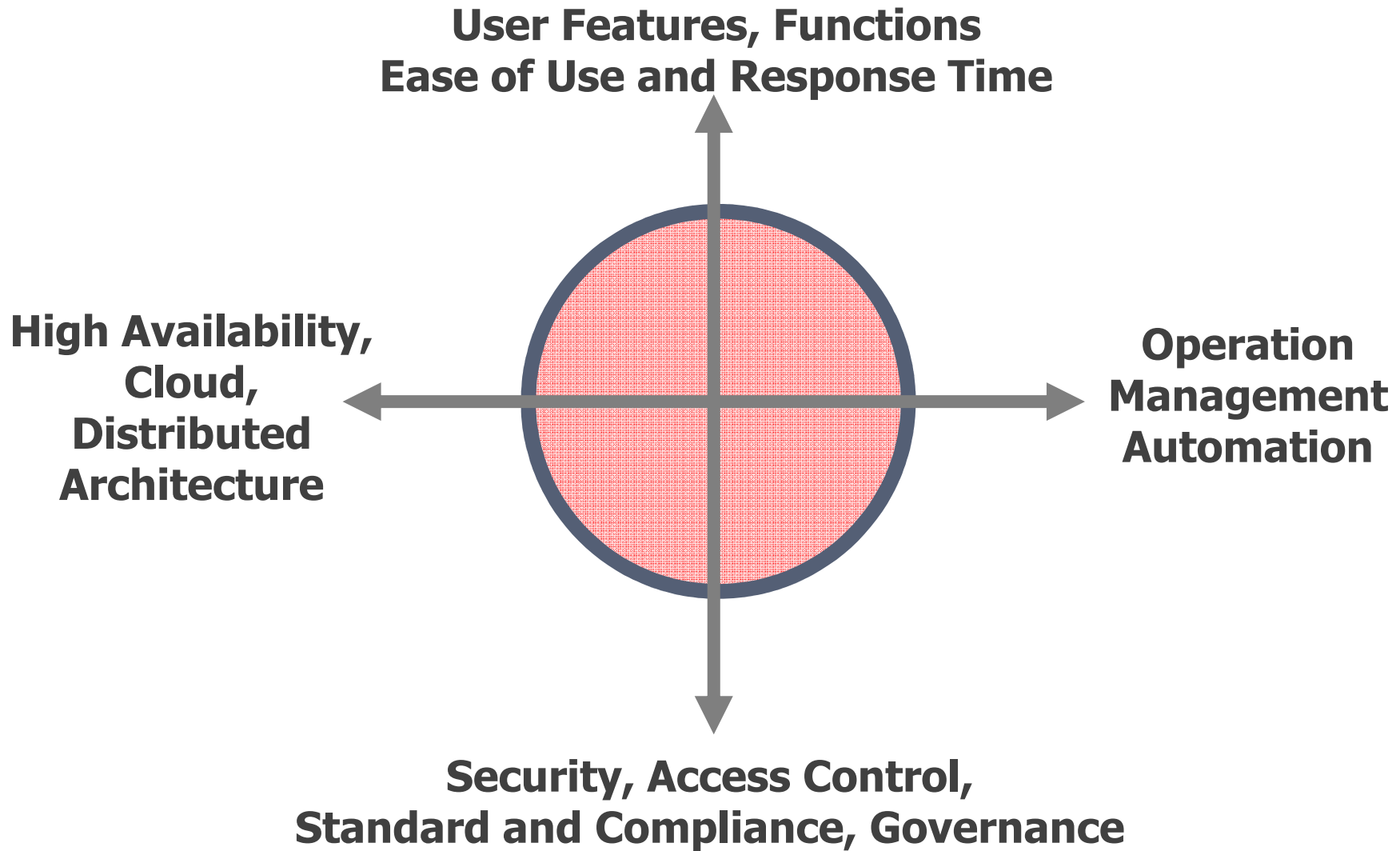

Logical Configuration Management Model

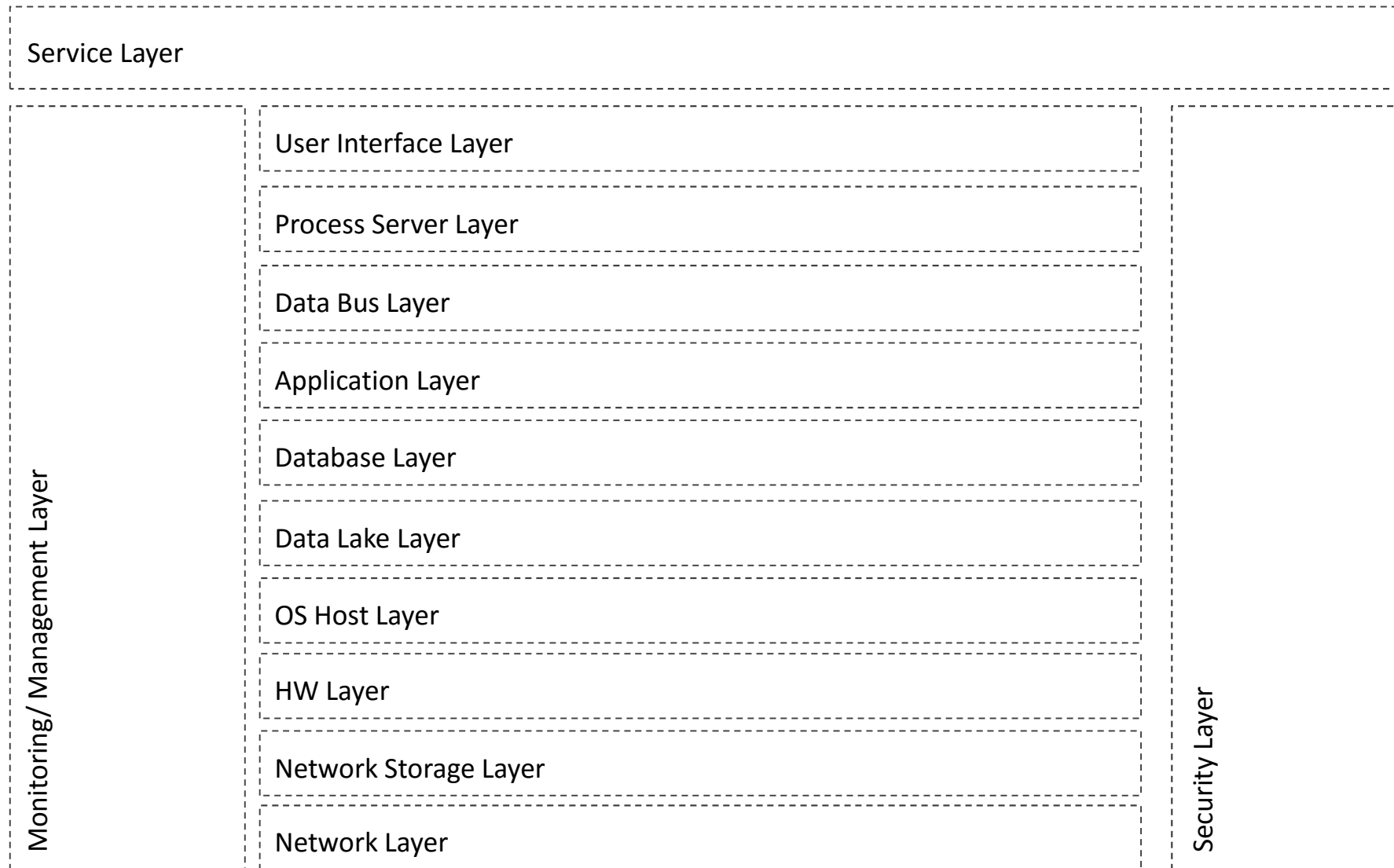

Logical Configuration Management Model

Example – HR Service

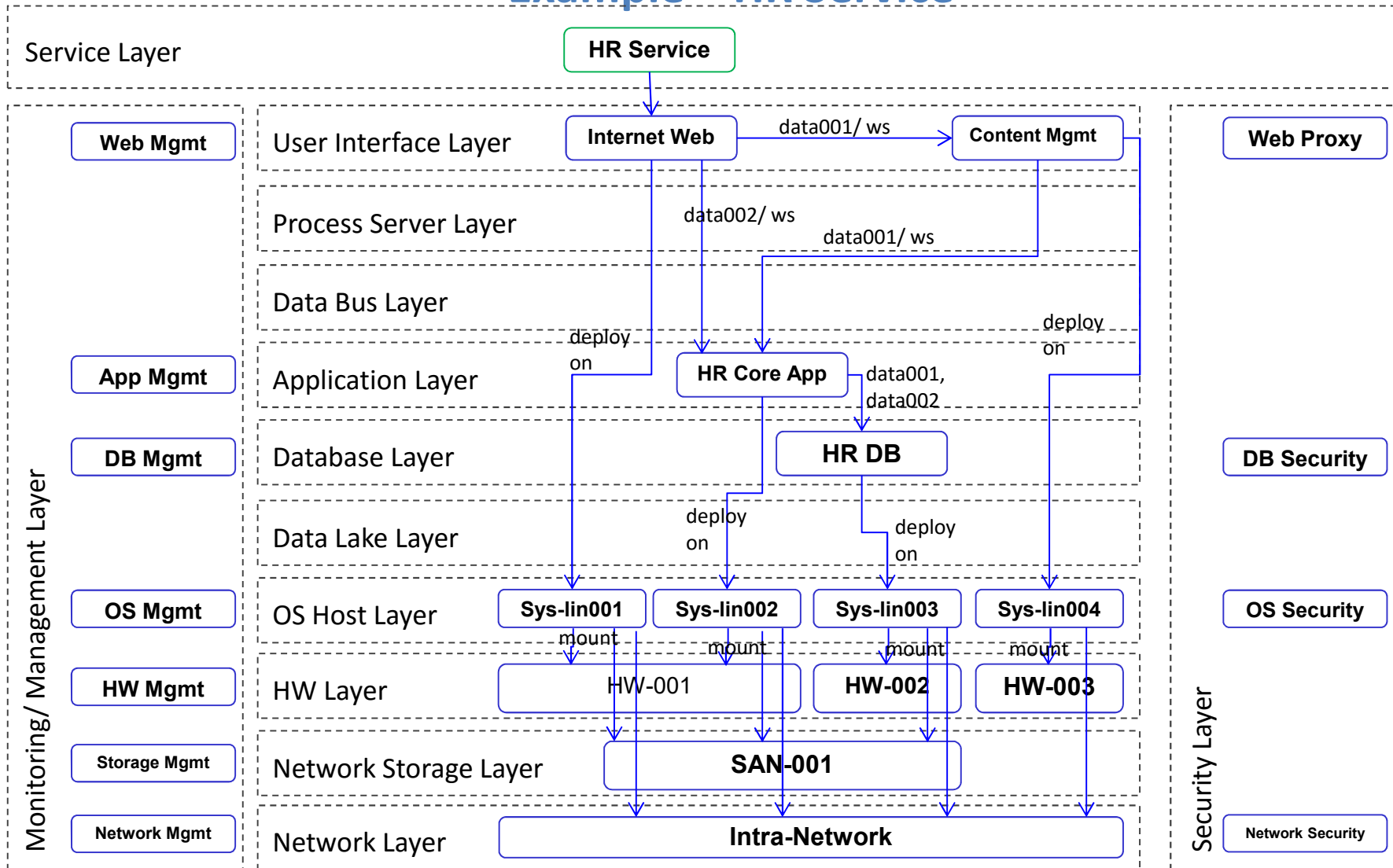

Enterprise Repository

Owner: Business Units

Business Objectives Worksheet

Version: ___ Date: _____

#	Business Goals	Business Services	Business Objectives	Owner	Business Processes	Remarks

Business Processes Worksheet

Version: ___ Date: _____

#	Business Process Name	Owner	Strategic Business Process (Y/N)	Main Service Description	High Level Business Process (Please attach up-to-date document)	Expected Transaction Complete Duration (hr,day,week)	Actual Transaction Complete Duration (hr,day,week)	Total of Transaction / (hr, day, month)	% of Transaction Duration done by automated system	Supported by Application(s)	Current Issues	Remarks



Enterprise Repository

Owner: Technology Unit

Applications/Touch Points Worksheet

Version: ___ Date: _____

#	Applications / Touch Points Name	Owner	Activity Flow (please attach up-to-date document)	Integration to which systems (online/batch)	Major Data Required	Current Issues	Remarks

Owner: Business Unit with supported by Technology Unit

Data Worksheet

Version: ___ Date: _____

#	Data Name	Owner	Description	Change Control of data (Y/N)	Structure/ Unstructure	Data Type (DB, JSON, XML, Sound, Image, VDO, etc.)	Current Issues	Ramarks

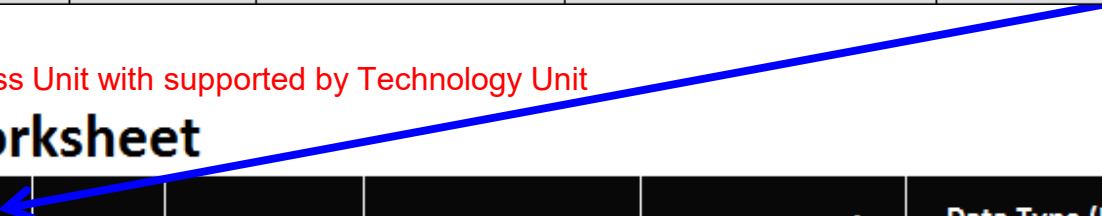

Group Workshop - Enterprise Reference Model

The Future State

15 mins.
presentation

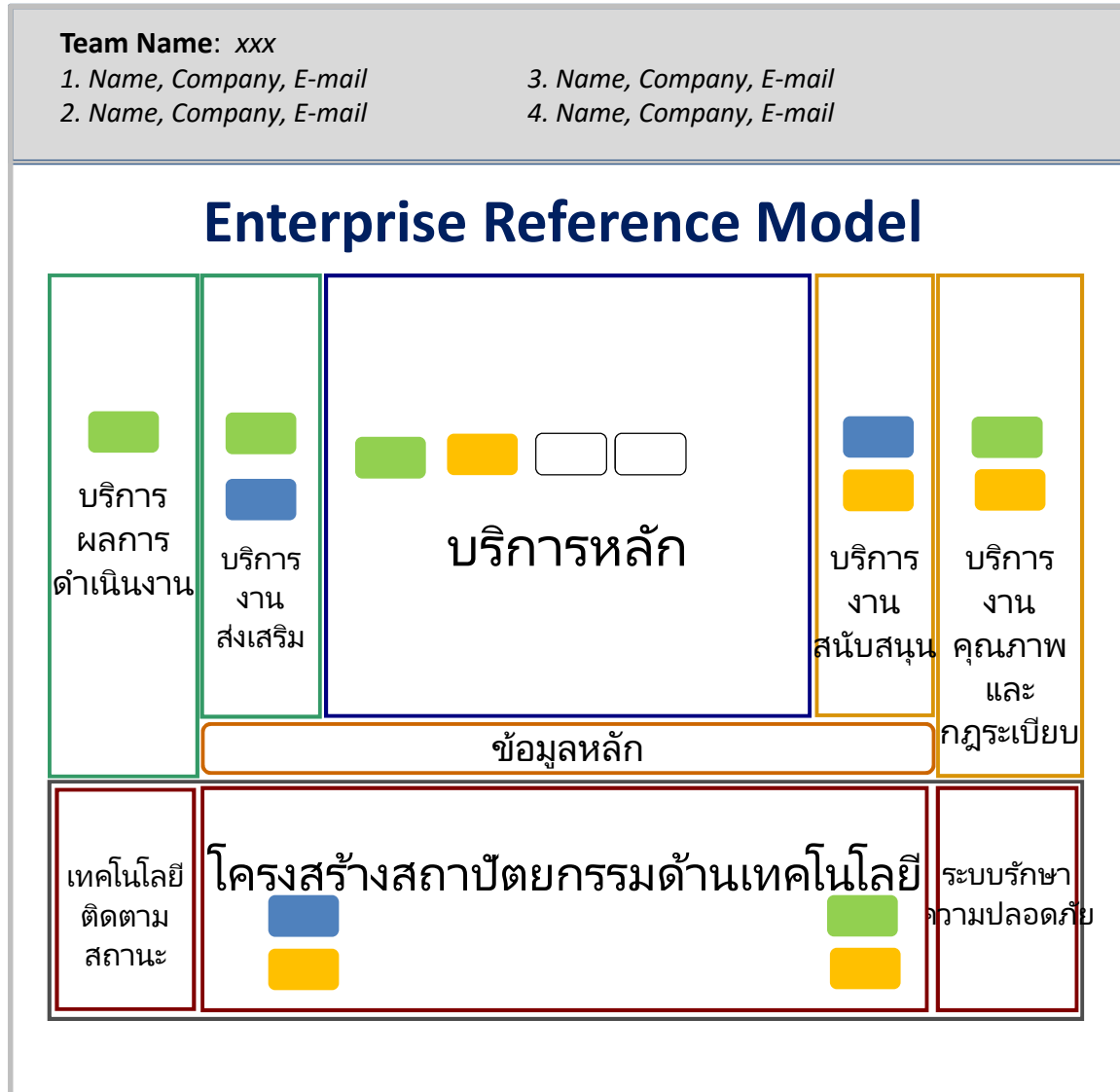
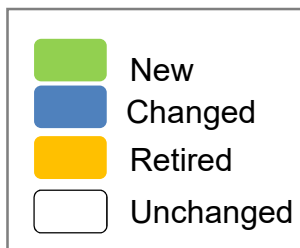

Thank you.

Together we can!

อ.दनัยรัฐ ธนบดีธรรมจารี
+668-1559-1446 Line ID: danairat
FB: <https://www.facebook.com/tdanairat>